

OPTIMUS PRIME

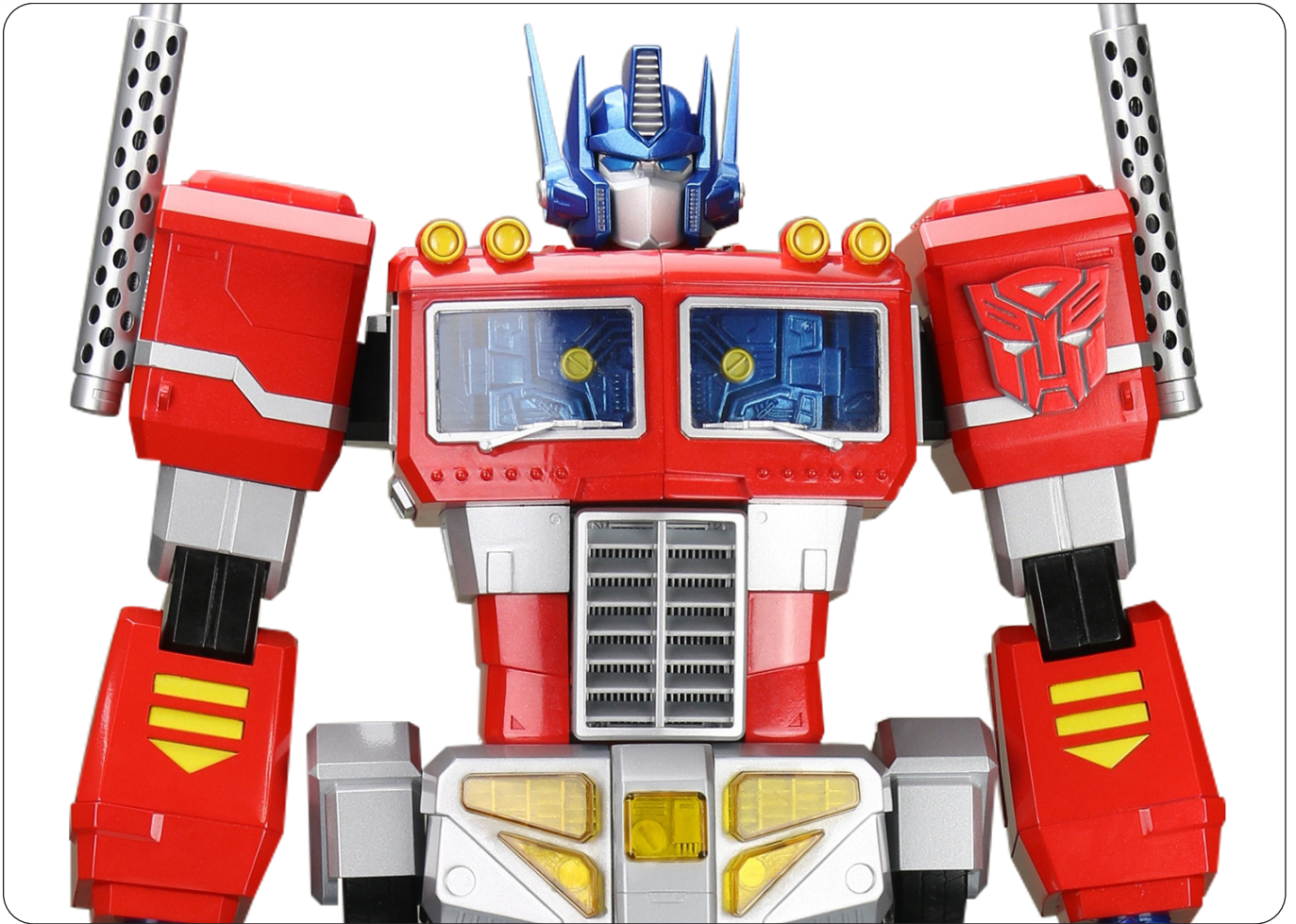

Pack 12: Body

BUILD INSTRUCTIONS

AGORA
MODELS®

Advice from the experts

 **Please keep ALL unused screws as they may be required in a later stage.**

Please make sure you don't mix up the screws. They look quite similar, but the threads do vary slightly. Using the wrong screws may damage the parts.

When securing parts together using multiple screws, fit each screw loosely to ensure all the parts are correctly aligned before gently tightening them firmly, but not overtight, in the order in which you placed them.

The screwdriver can be magnetized by stroking it with a magnet (fridge magnet, etc.) enabling it to hold the screws and make assembly easier.

If a screw is tight going into a metal part, do not force it as you may shear the head off. Remove it and put a tiny smear of Vaseline, soap or light oil on the thread. That will lubricate it and make it easier to drive home.

Some parts will require a little glue for assembly. Please apply glue sparingly and use a cocktail stick so that you don't use too much nor apply the glue too heavily. We recommend superglue gel or Extra Thin Liquid modeling glue. Where possible, parts should be test-fitted in place before gluing.



Look out for the glue symbol and apply glue to the red area indicated in the picture.

During the course of this build, you will receive many pieces that you will assemble immediately – following the instructions in the corresponding stage – and other pieces that you should store in the tray supplied, for use in future assembly stages.

Always protect the paint finish on components by placing a cutting mat, sheet of white paper or soft cloth on your work surface.

Left and Right! When building your Optimus Prime, the left or right hand side refers to each side as viewed by Optimus Prime. Optimus Prime's left arm is on the viewer's right.



WARNING: Some parts are assembled using magnets. These magnets can cause serious injury if they are swallowed. Keep away from children. If you suspect a magnet has been swallowed, seek medical help straight away.

Pack 12 Parts

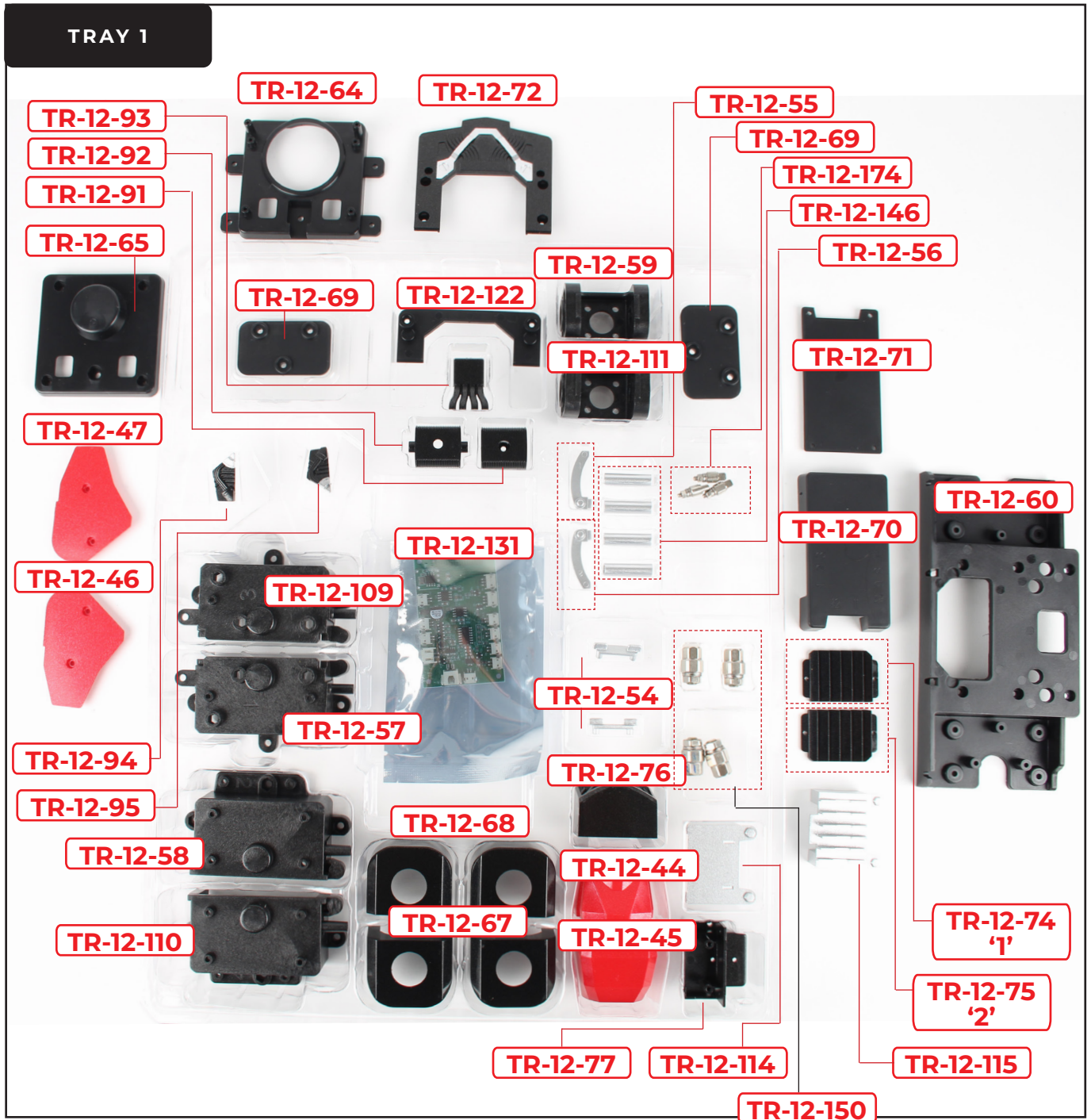

Pack 12 Parts

TRAY 2

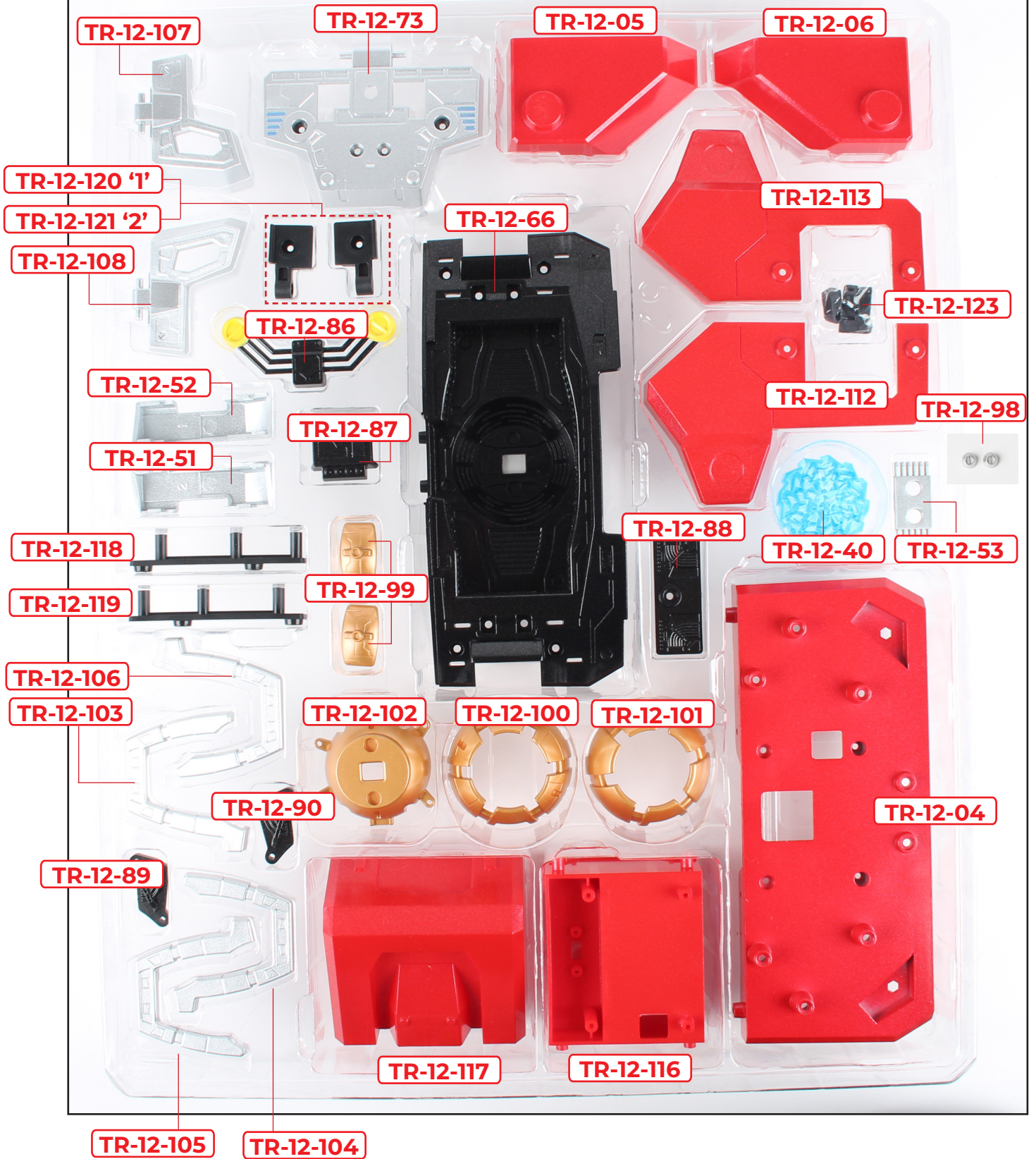

Pack 12 Parts

TRAY 2: Continued...

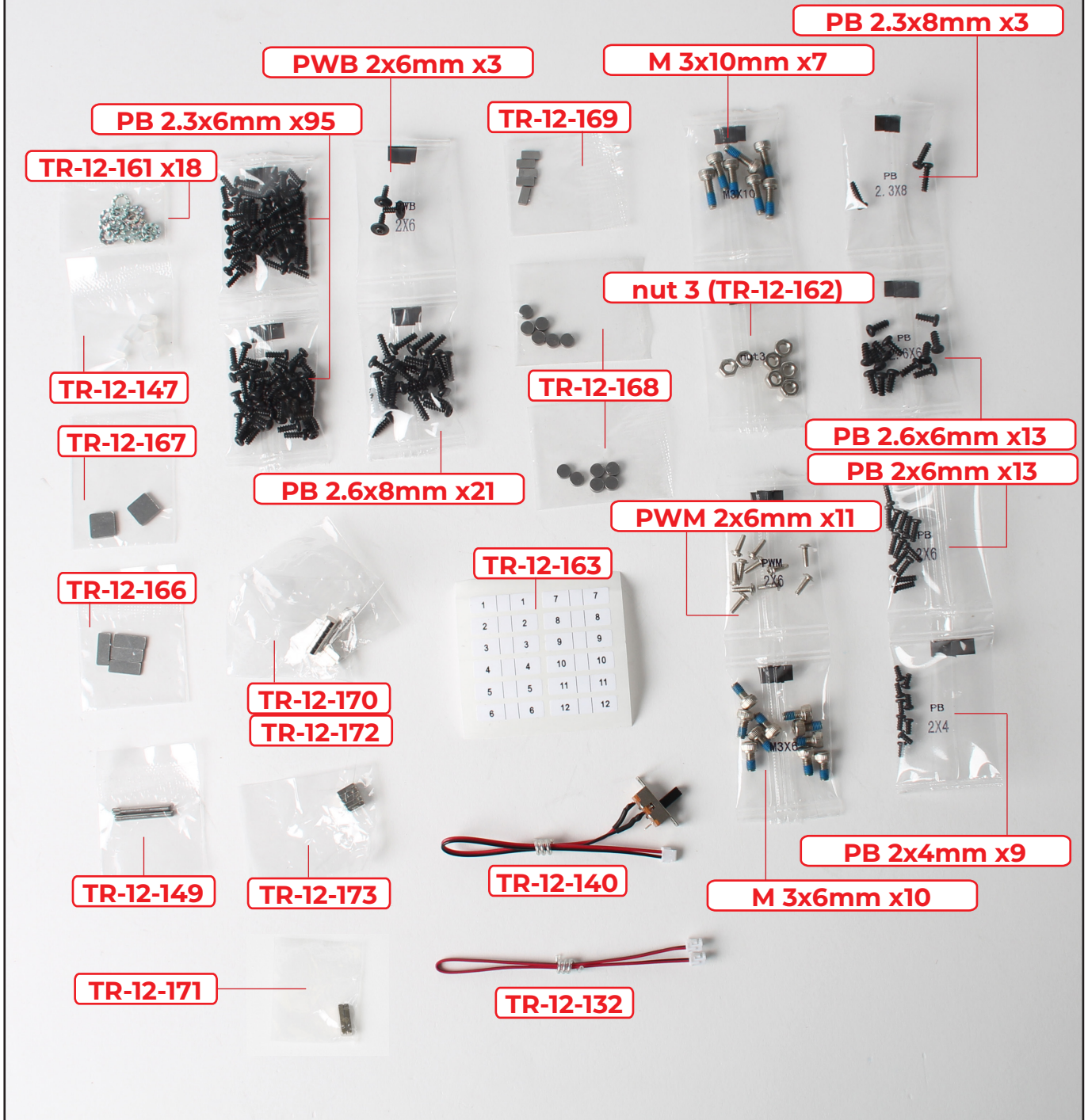

Pack 12 Parts

TRAY 3

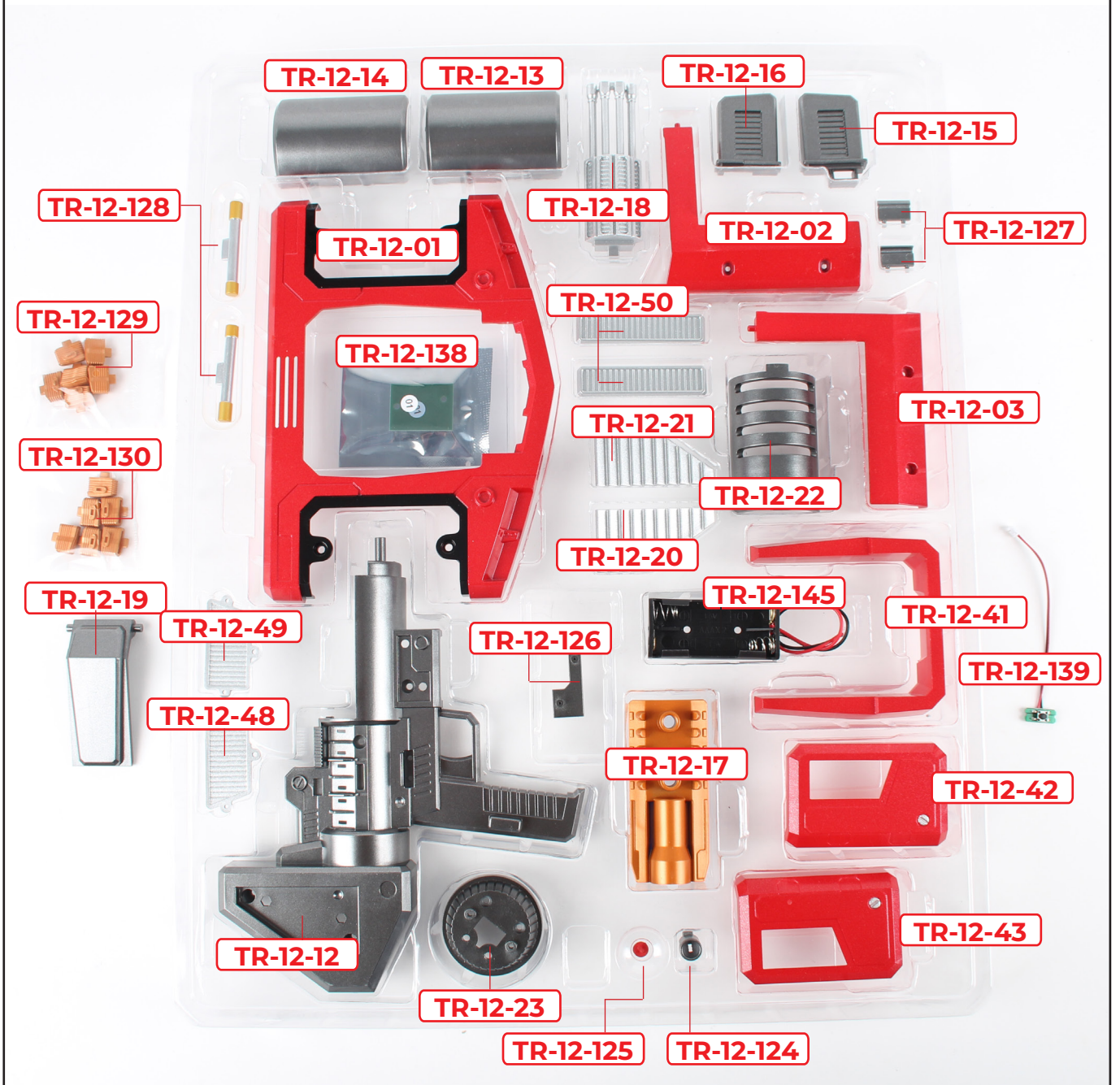

Pack 12 Parts

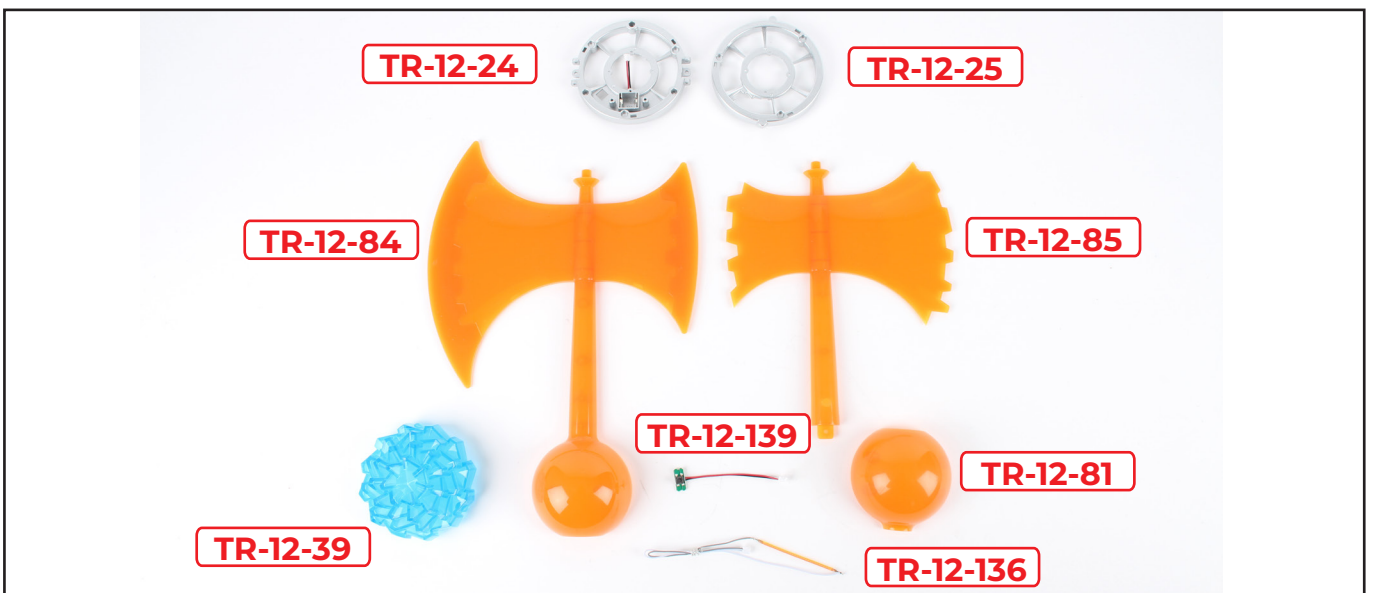
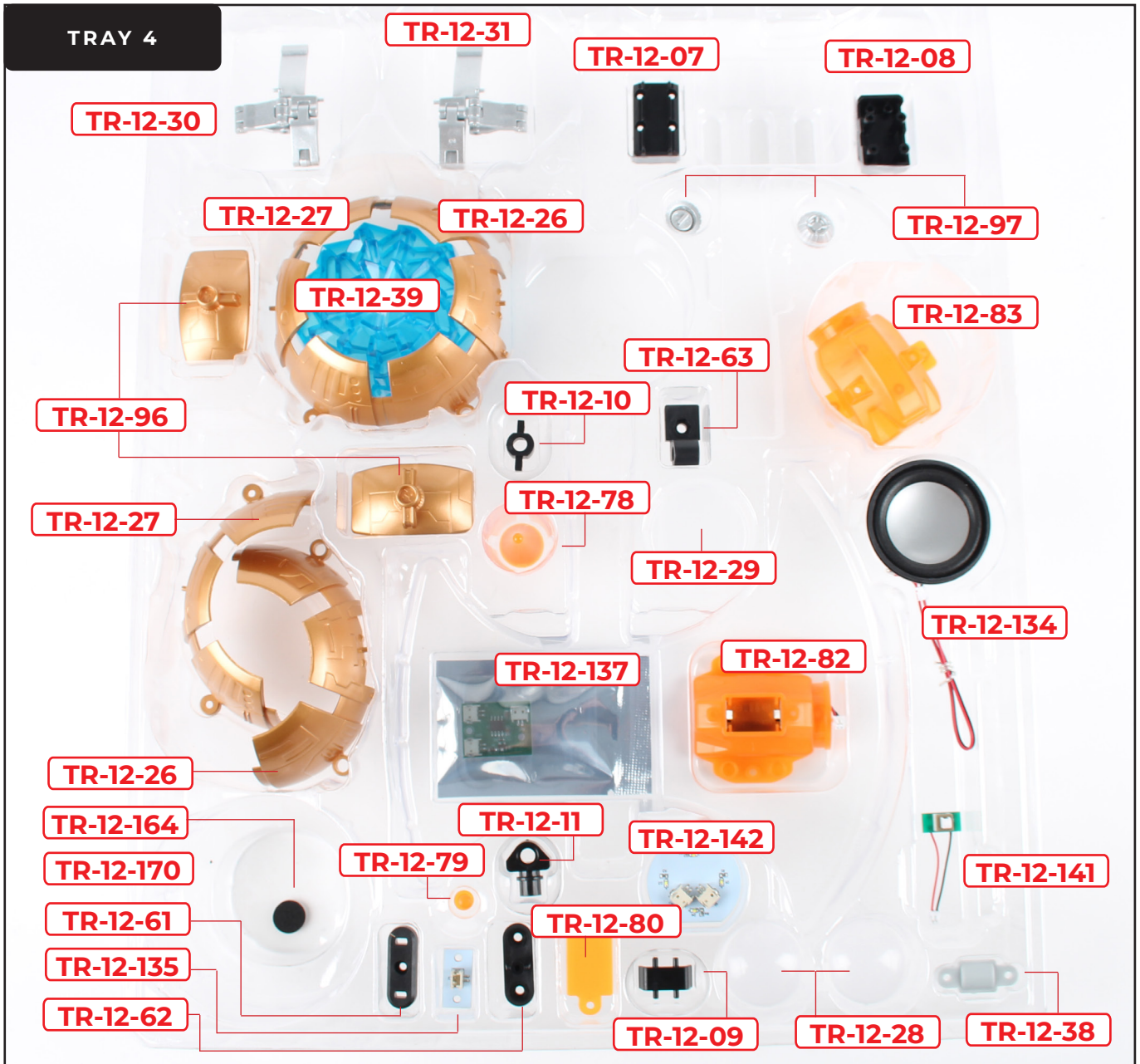

Assembling Components for the Back

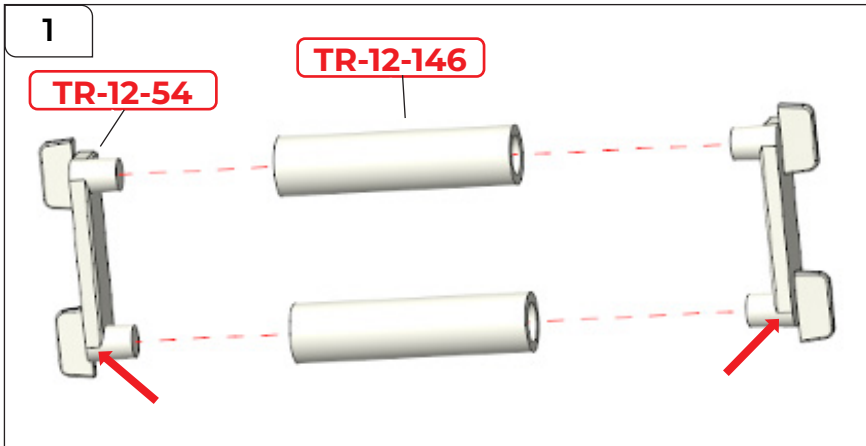

STEP 1

Take 2x TR-12-146 and push TR-12-54 into both ends as shown. Pay attention to the orientation of part 54 - the ends are different (red arrow).

STEP 2

Place the assembled parts into TR-12-115 to make assembly A.

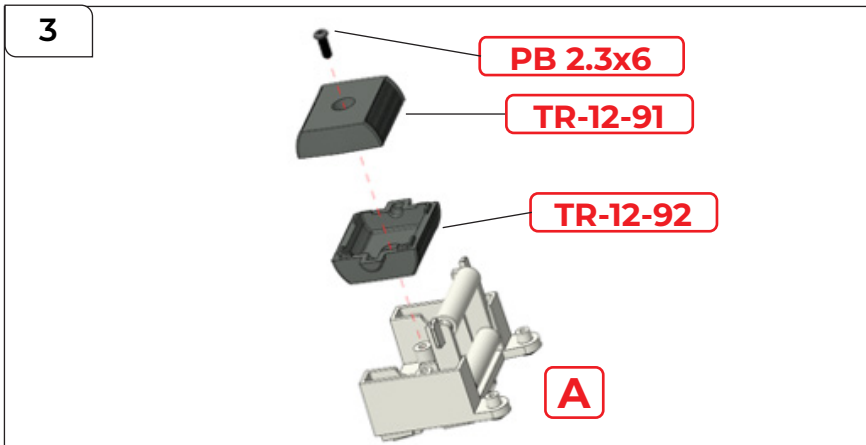
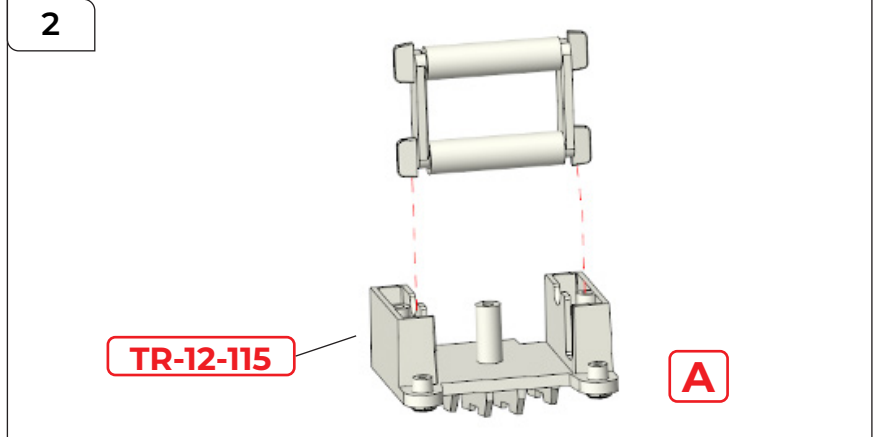

STEP 3

Attach TR-12-91 and TR-12-92 to A, then secure them with a PB 2.3x6 mm screw.

STEP 4

Take TR-12-114 and apply a little glue as indicated in red. Attach TR-12-146 and TR-12-114 to A.

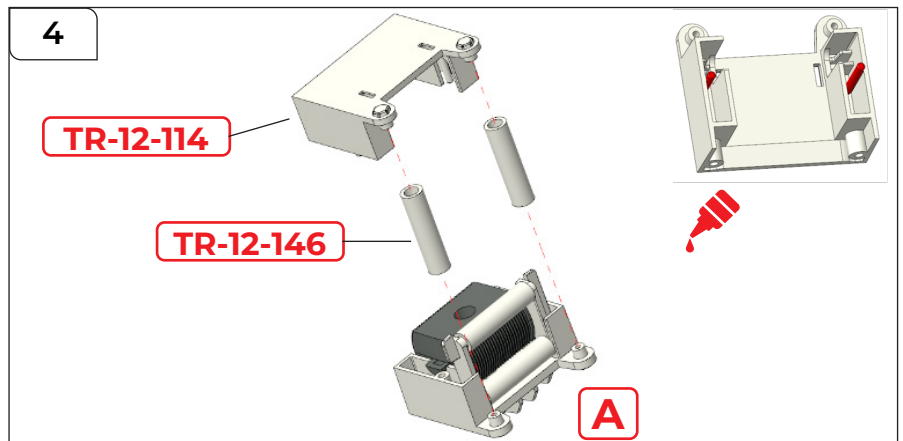

Assembling Components for the Back

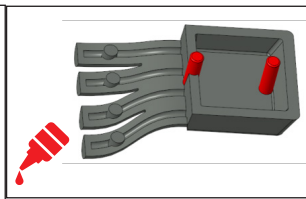
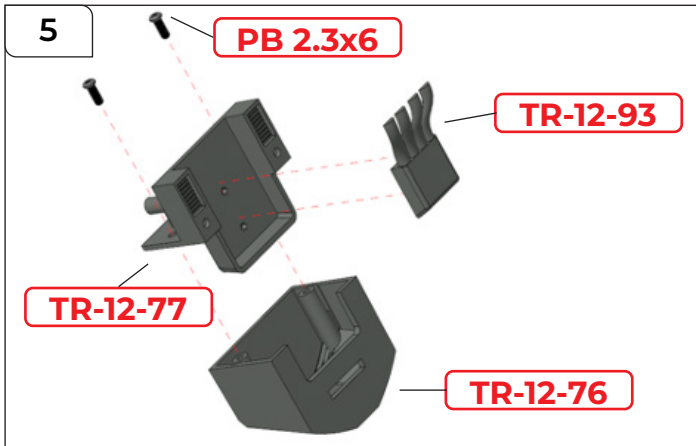

STEP 5

Apply a little glue to TR-12-93 before fixing it to TR-12-77, then attach the assembly to TR-12-76. Secure the parts together using 2x PB 2.3x6 mm screws.

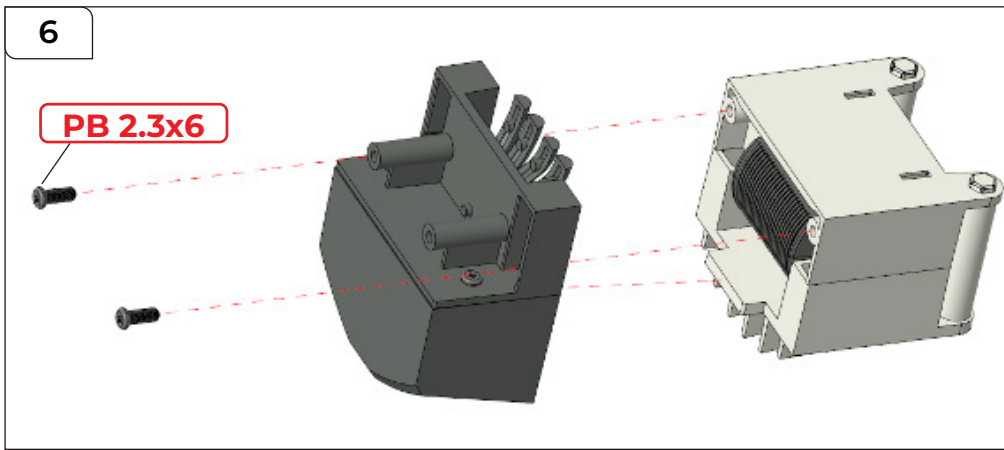

STEP 6

Attach the assemblies from steps 4 and 5 together using 2x PB 2.3x6 mm screws.

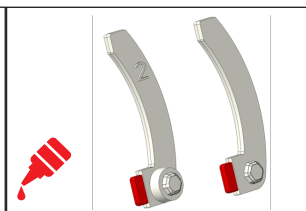
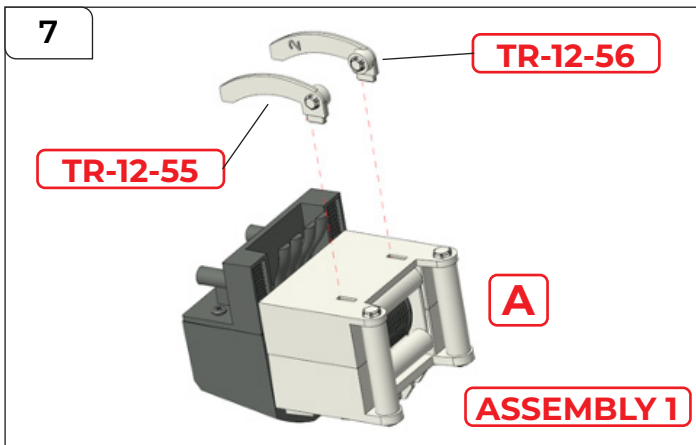

STEP 7

Apply a little glue to TR-12-56 and fit them to A. This assembly will be referred to later as ASSEMBLY 1.

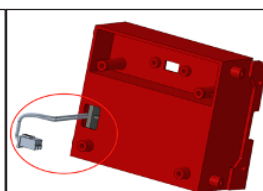
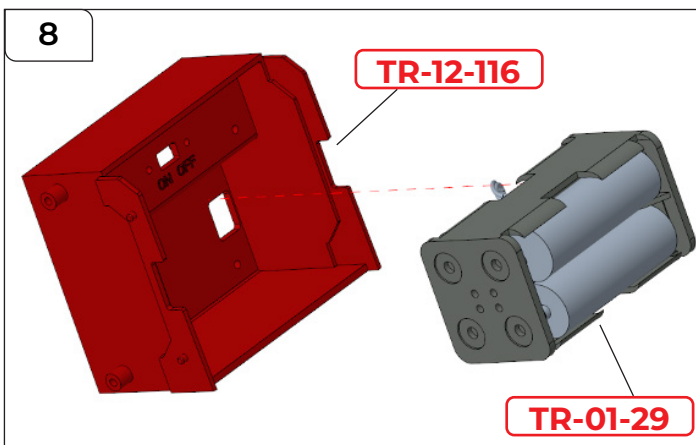

STEP 8

Retrieve the battery compartment supplied with pack 1 (TR-01-29) and insert 2x AAA (1.5V) batteries. Fit the compartment to TR-12-116, passing the cable through the opening at the back.

Assembling Components for the Back

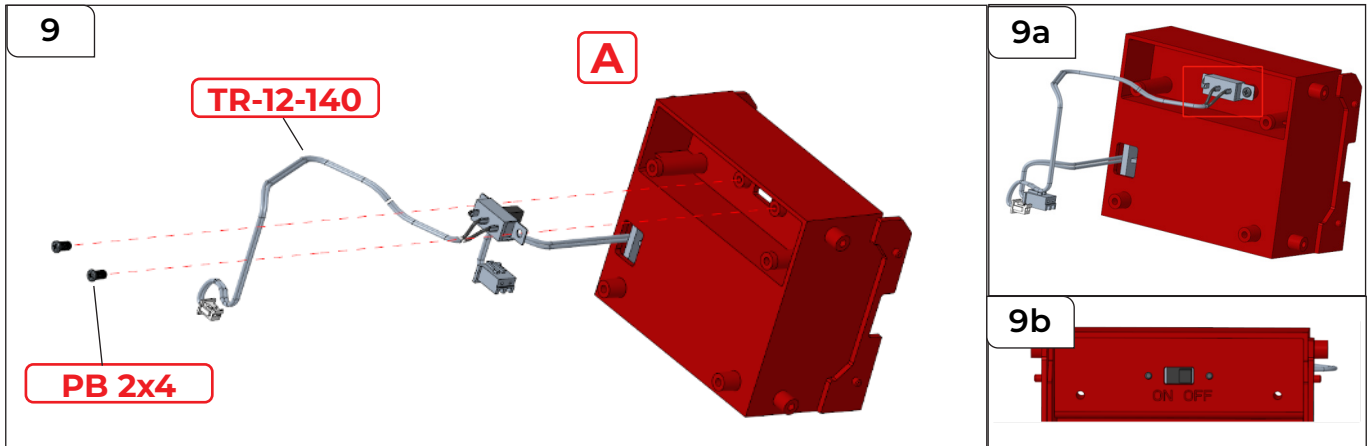

STEP 9

Fit TR-12-140 to A and secure it using 2x PB 2x4mm screws. This forms the ON/OFF switch as shown in 9b. Check the switch is able to slide left and right.

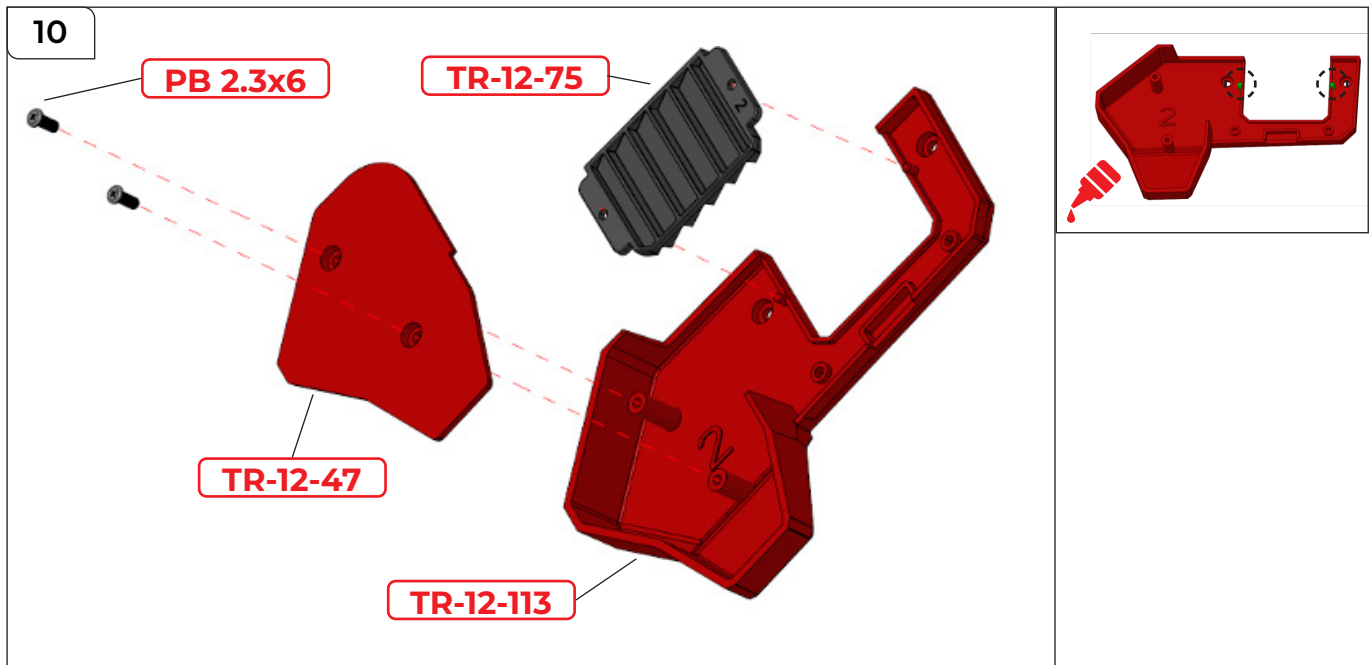

STEP 10

Glue part TR-12-113 as shown, then attach TR-12-75. Attach TR-12-47 (marked "2") and secure using 2x PB 2.3x6 mm screws.

Assembling Components for the Back

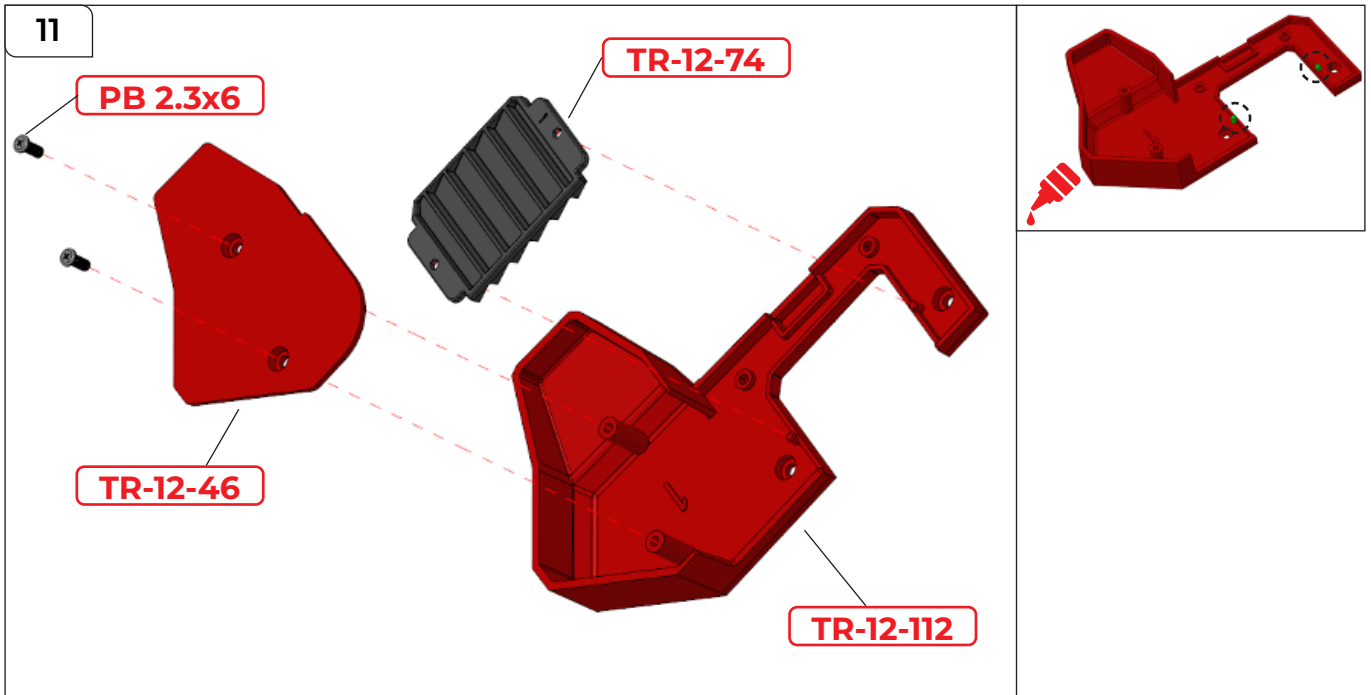

STEP 11

Repeat to assemble TR-12-112. Start by applying a little glue before attaching TR-12-74 followed by TR-12-46 (marked "1"), then secure using 2x PB 2.3x6 mm screws.

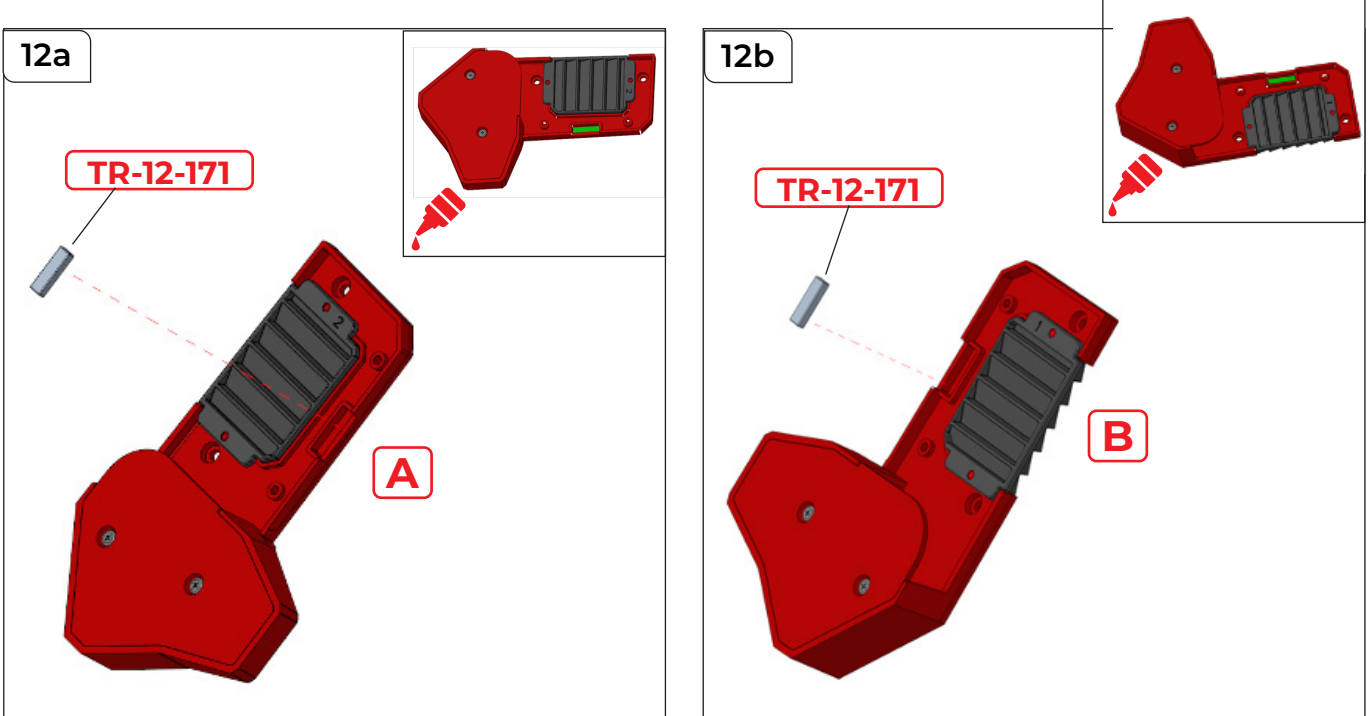

STEP 12

Take the assembly from step 10, apply a little glue to the recess and attach TR-12-171 to make 'A'. Repeat this process for the assembly from step 11 to make 'B'.

Assembling Components for the Back

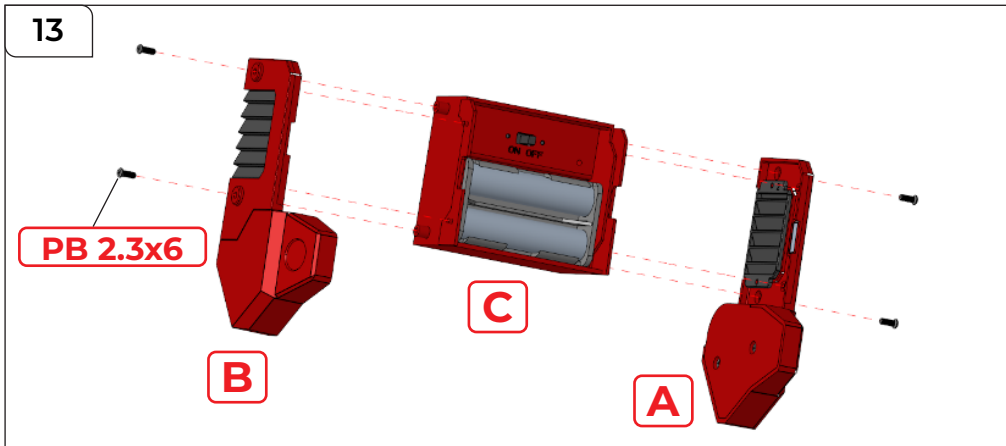

STEP 13

Fix A and B to the battery compartment C and secure them using 4x PB2.3x6 mm screws.

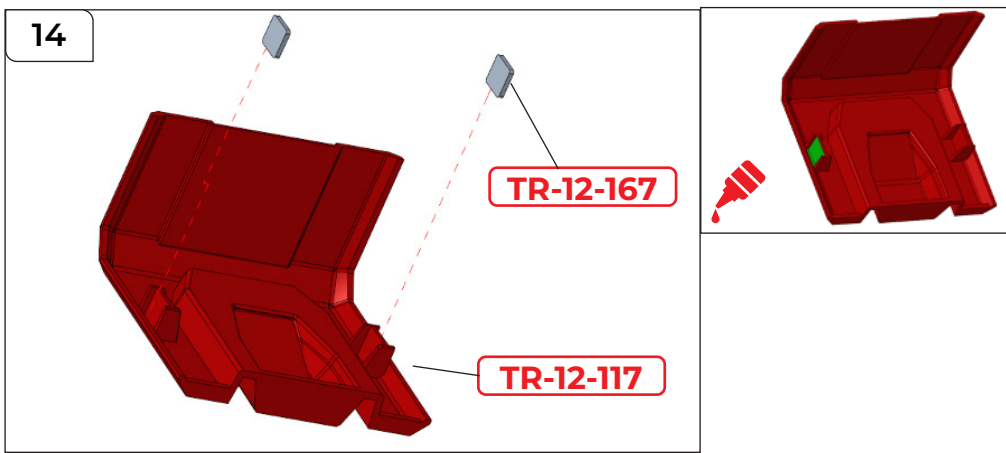

STEP 14

Apply glue to the outer face of the recesses on TR-12-117 before attaching 2x TR-12-167.

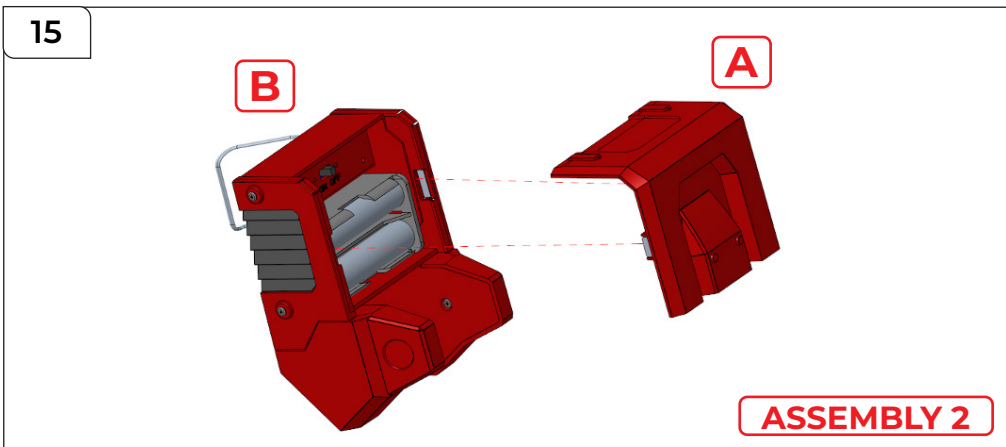

STEP 15

Attach assembly A to assembly B. This will be referred to later as ASSEMBLY 2.

Assembling Components for the Head

1

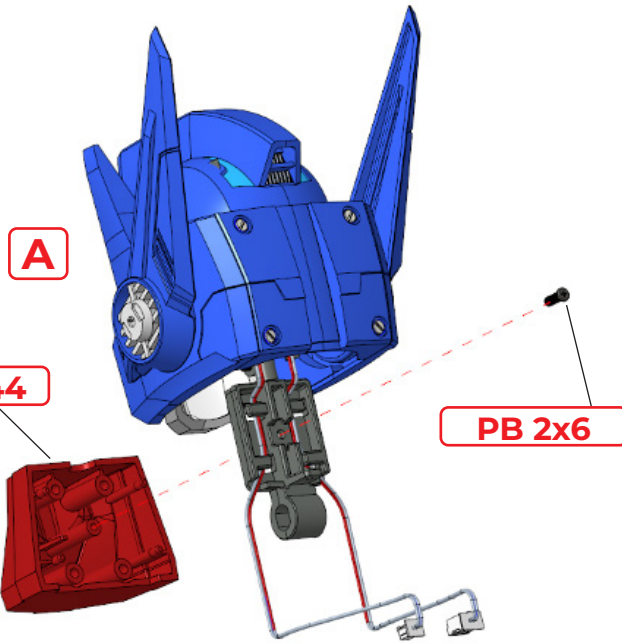

STEP 1

Take the head assembly from Pack 1 and fit part TR-12-44. Secure in place using a PB 2x6 mm screw.

2

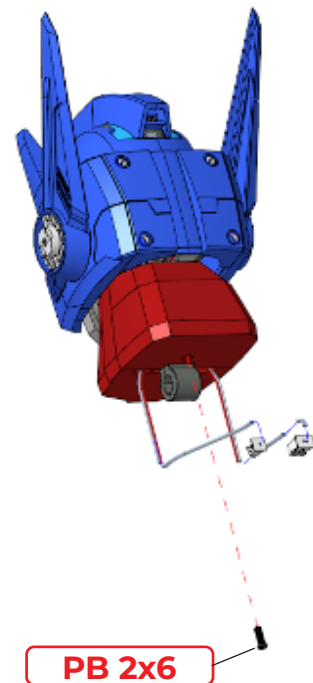
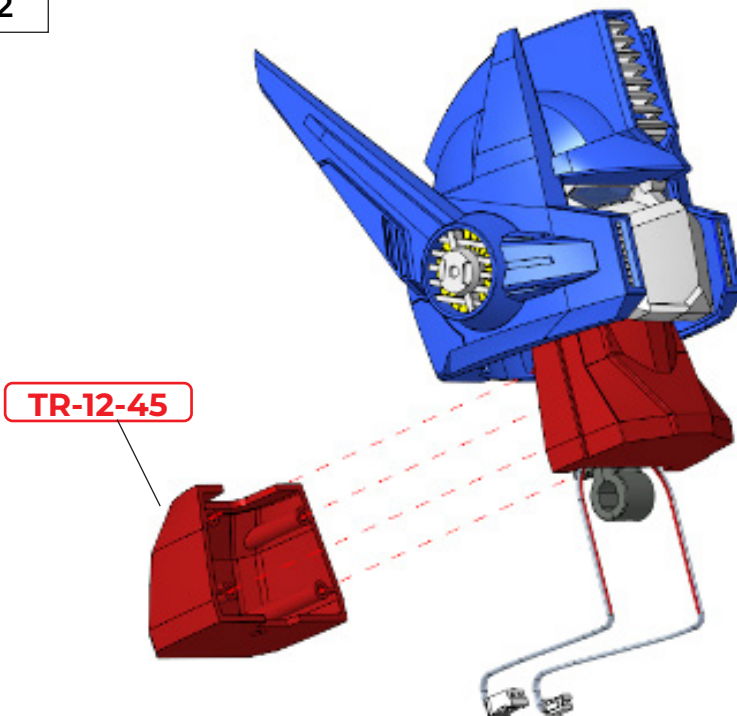

STEP 2

Fit TR-12-45 to the opposite side and secure using a PB 2x6 mm screw.

Assembling Components for the Head

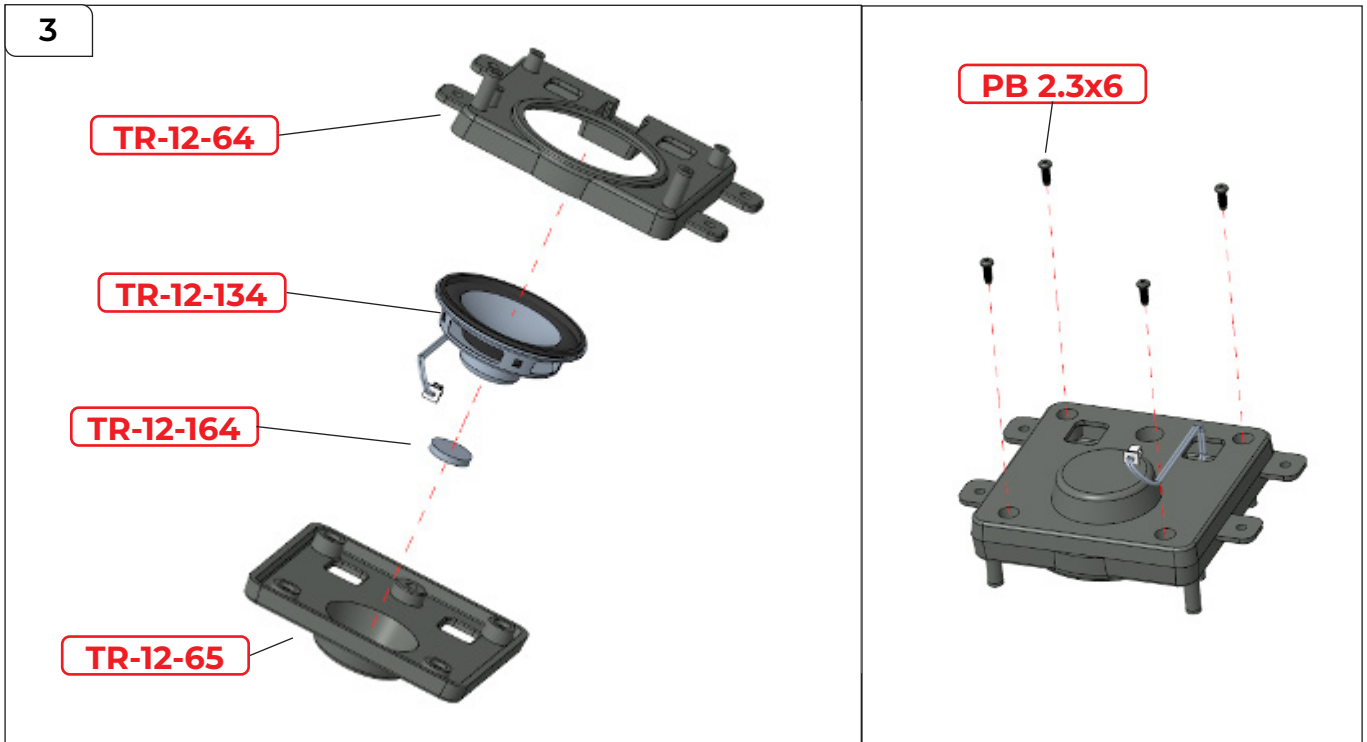

STEP 3

Fit TR-12-164 to TR-12-134, then attach to TR-12-65. Fit TR-12-64 on top and secure with 4x PB 2.3x6 mm screws.

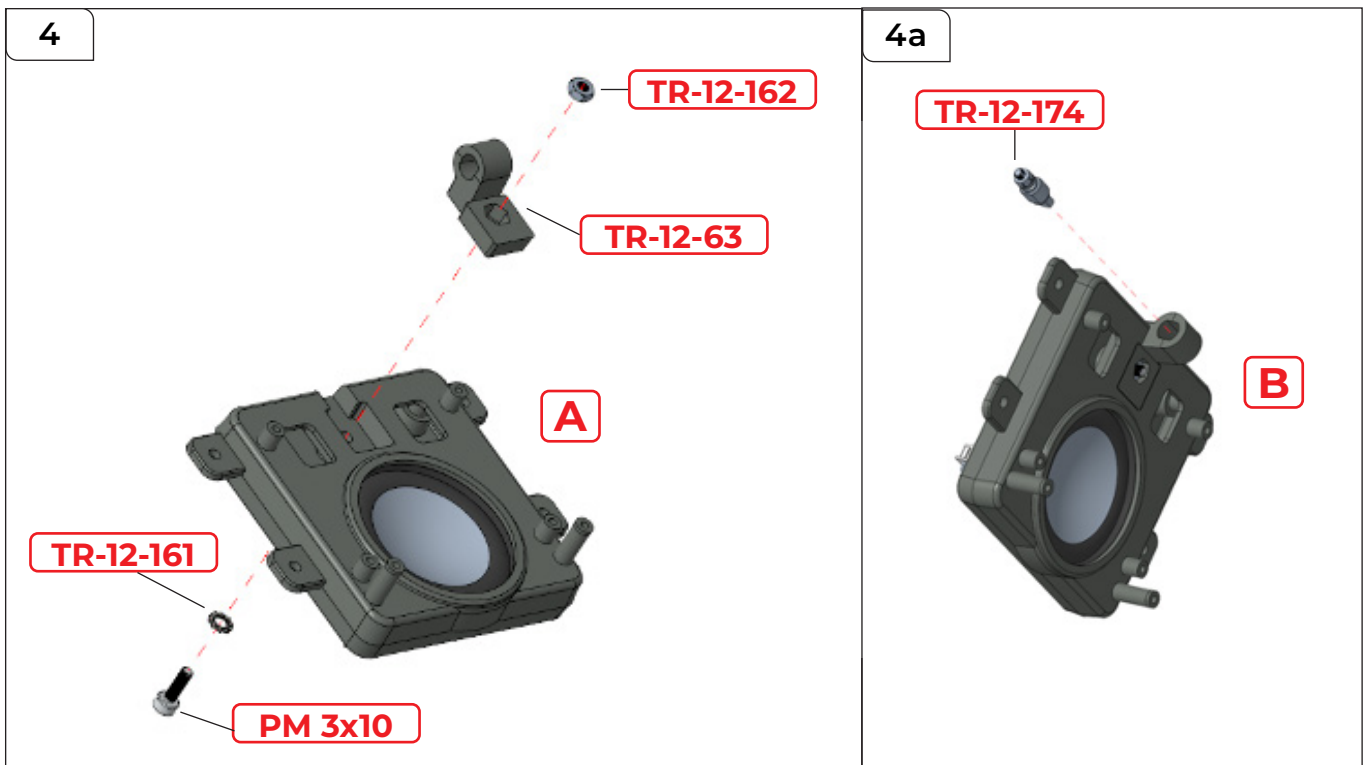

STEP 4

Fit TR-12-62 and TR-12-63 to A. Thread TR-12-161 onto a PM 3x10 screw and use them to secure assembly A. Then fit TR-12-174 to B.

Assembling Components for the Head

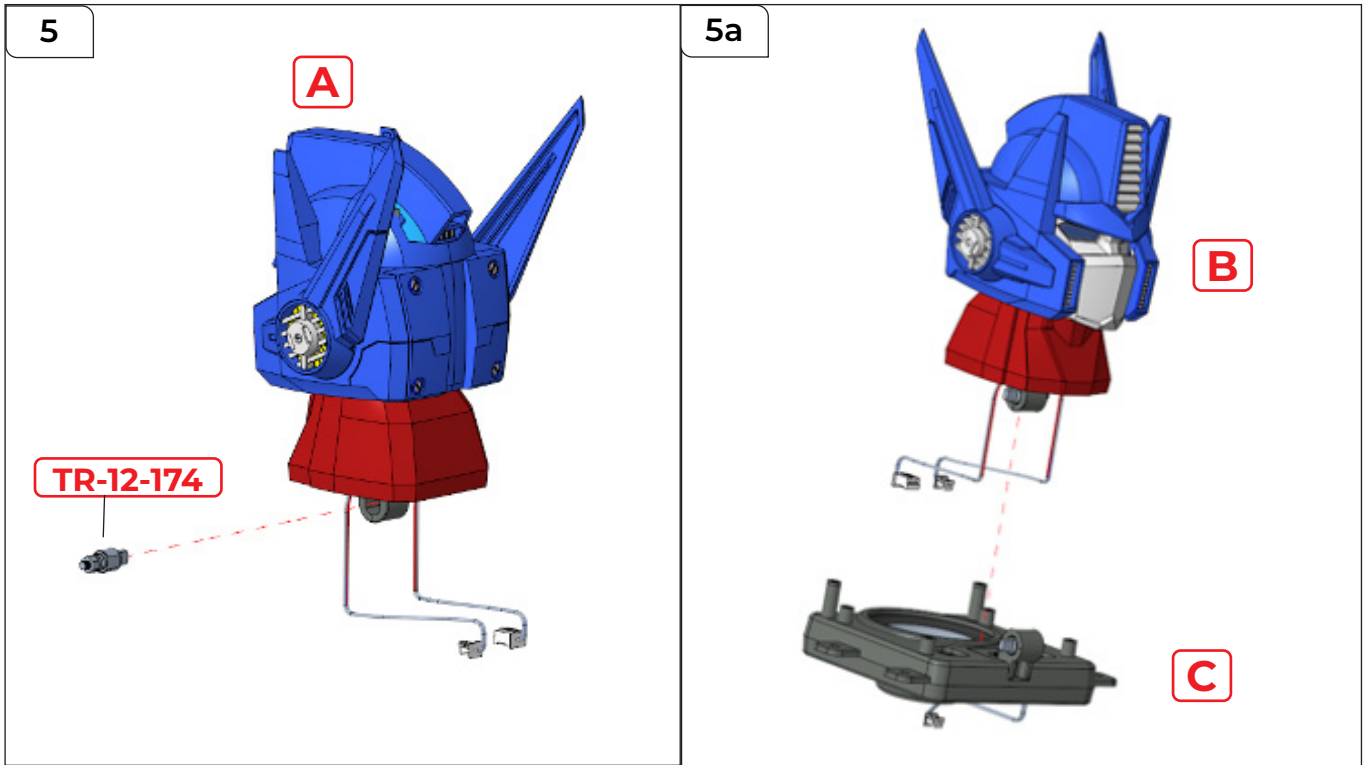

STEP 5

Fit TR-12-174 to A, then attach assembly C to assembly B.

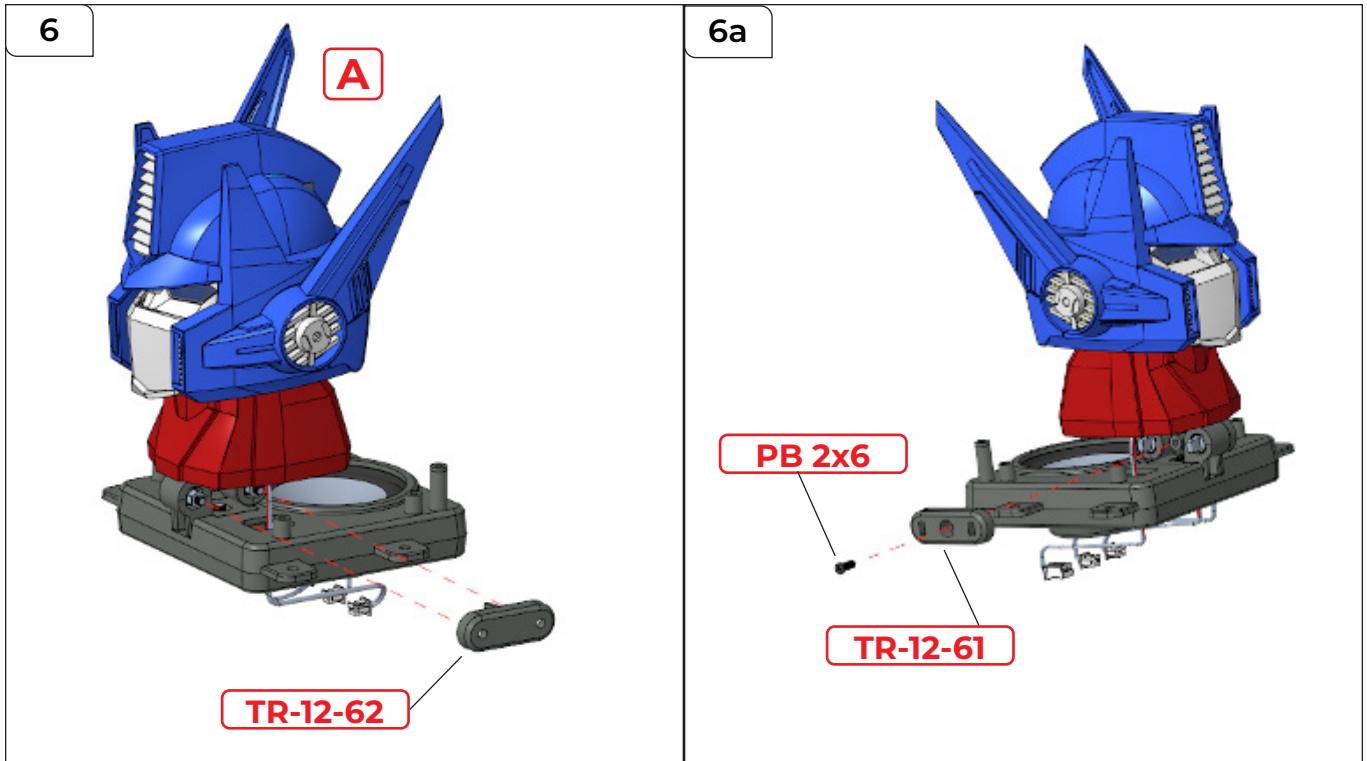

STEP 6

Fit TR-12-62 to A, then fit TR-12-61 (6a) and secure using a PB 2x6 mm screw.

Assembling Components for the Head

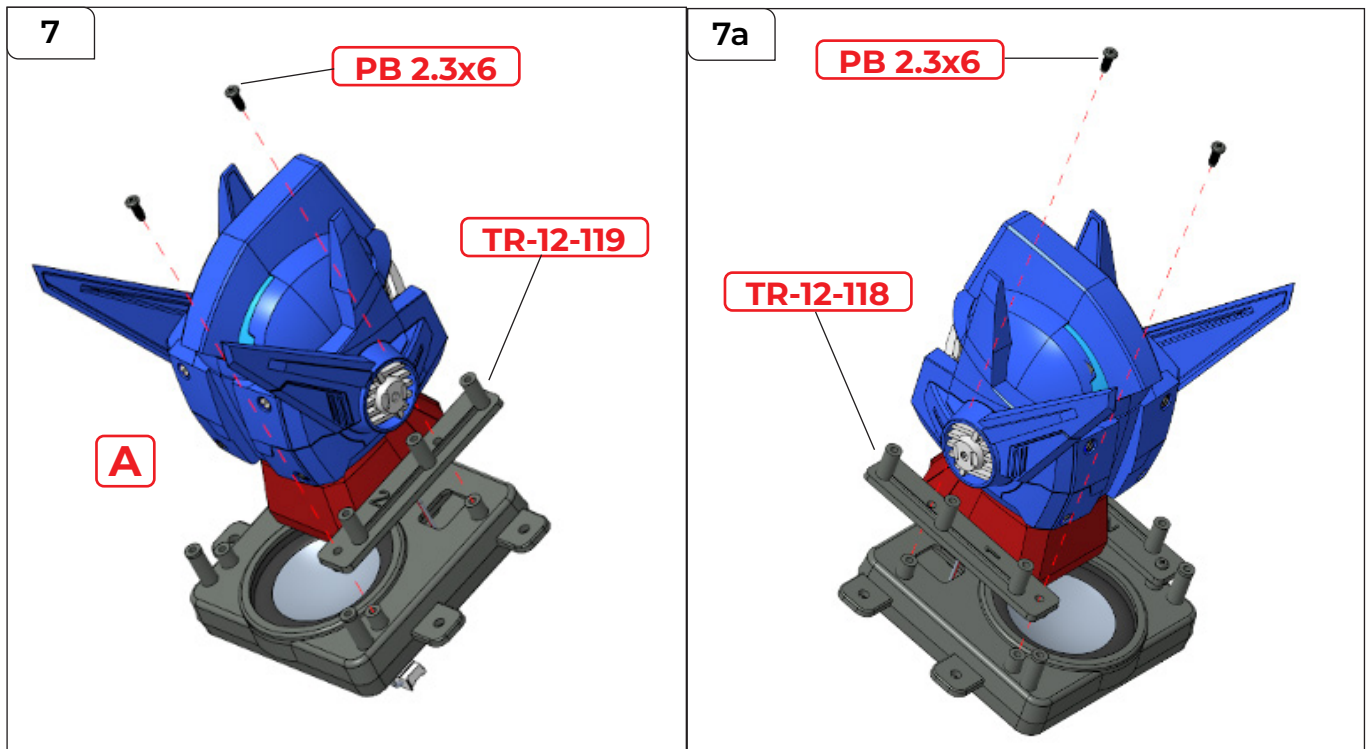

STEP 7

Fit TR-12-119 to A, then secure with 2x PB 2.3x6 mm screws. Fit TR-12-118 on the opposite side and secure with another 2x PB 2.3x6 mm screws.

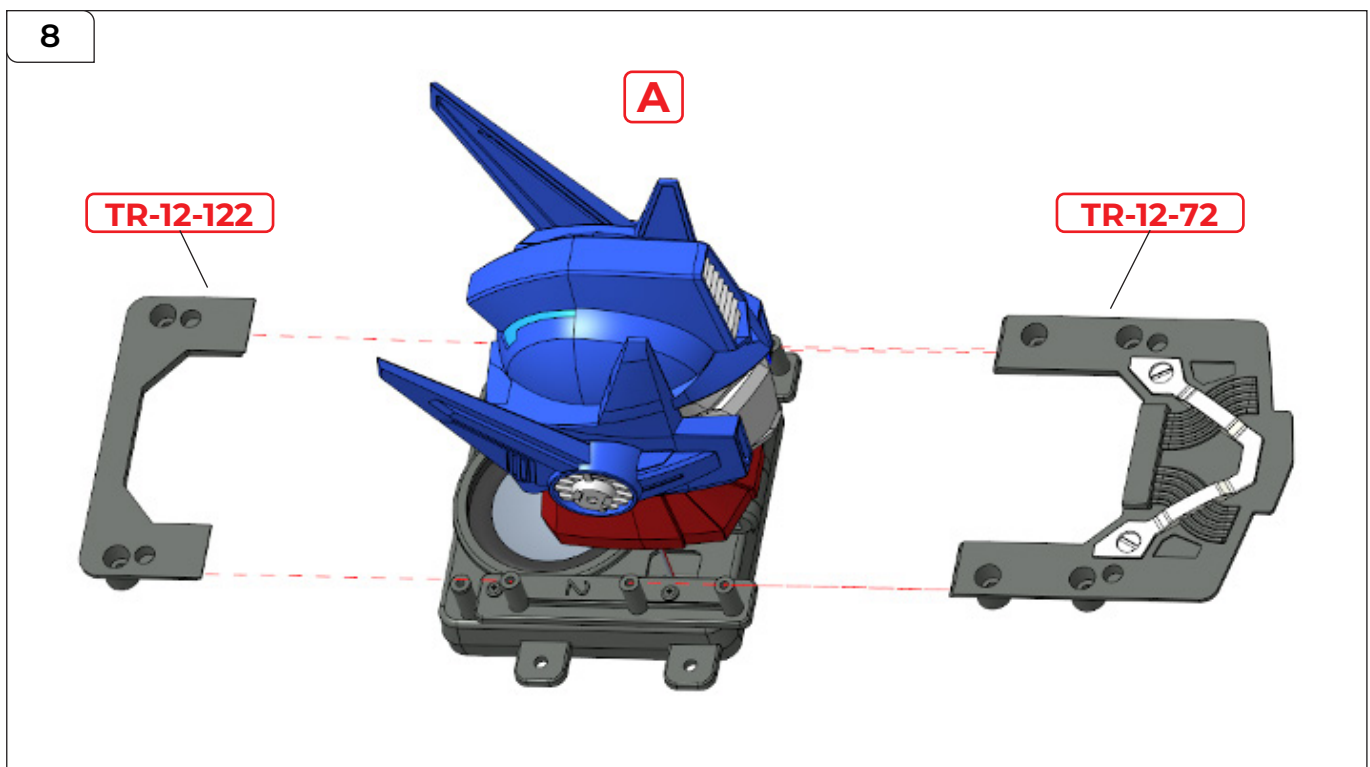

STEP 8

Fit TR-12-122 and TR-12-72 to A.

Assembling Components for the Head

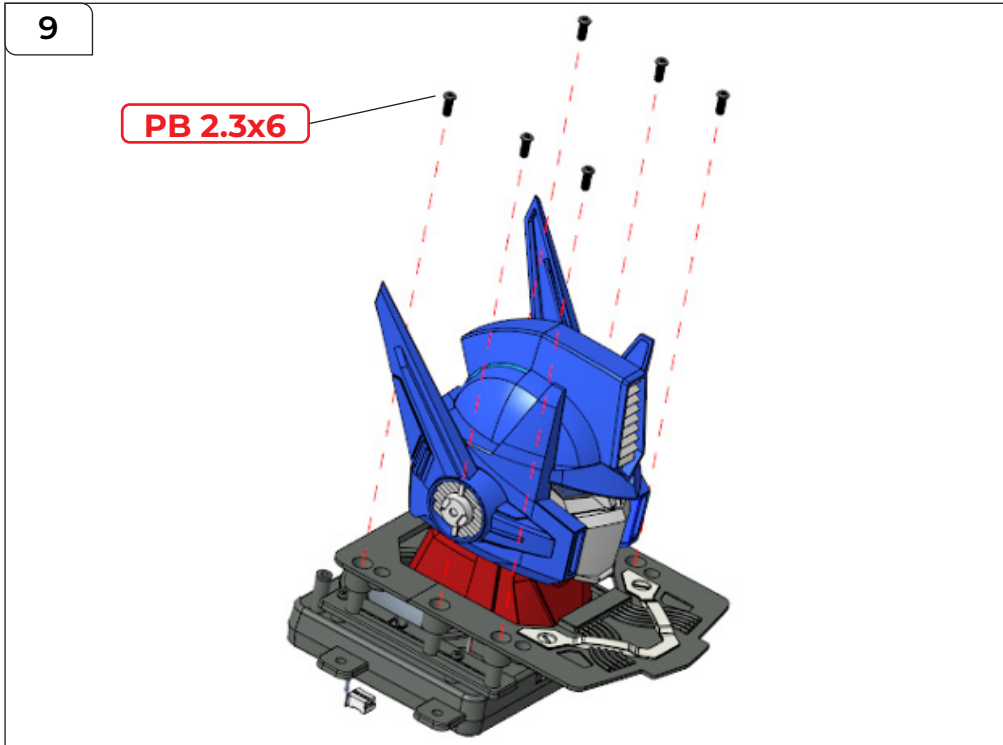

Continuing Assembly of the Back

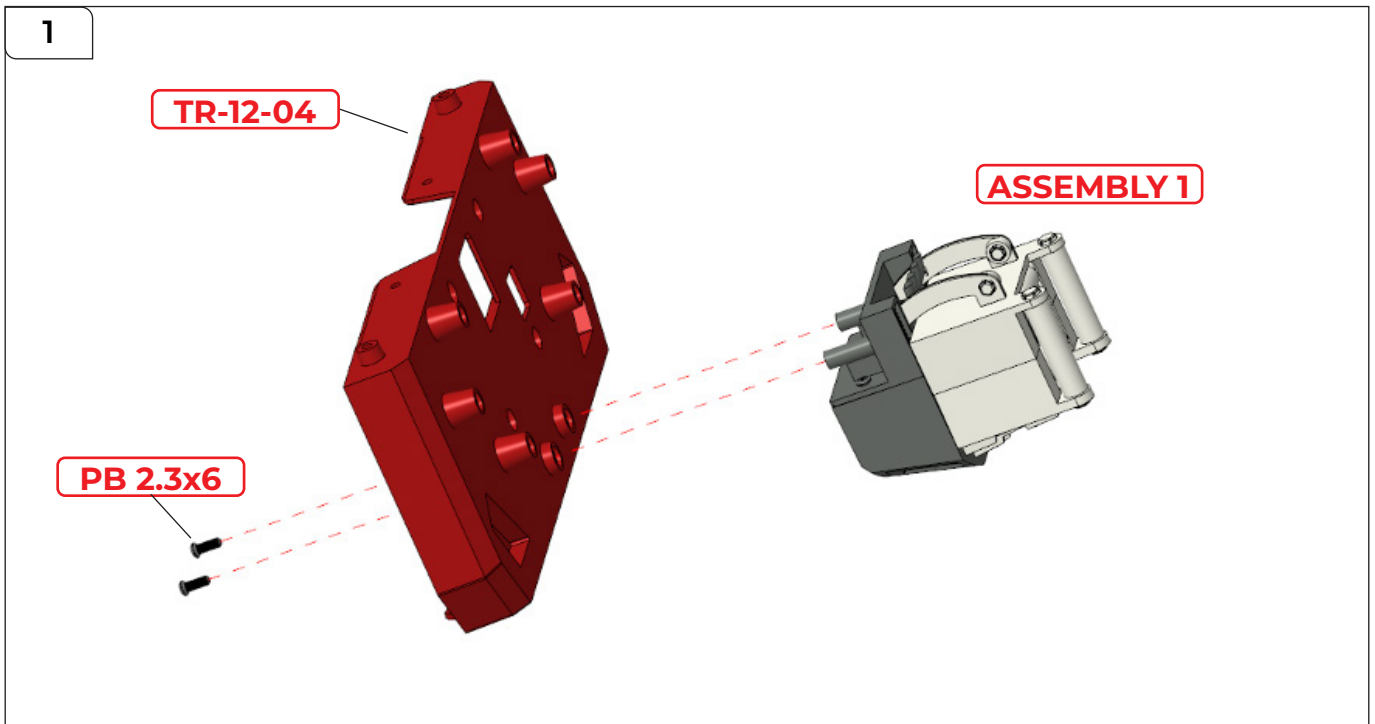

Continuing Assembly of the Back

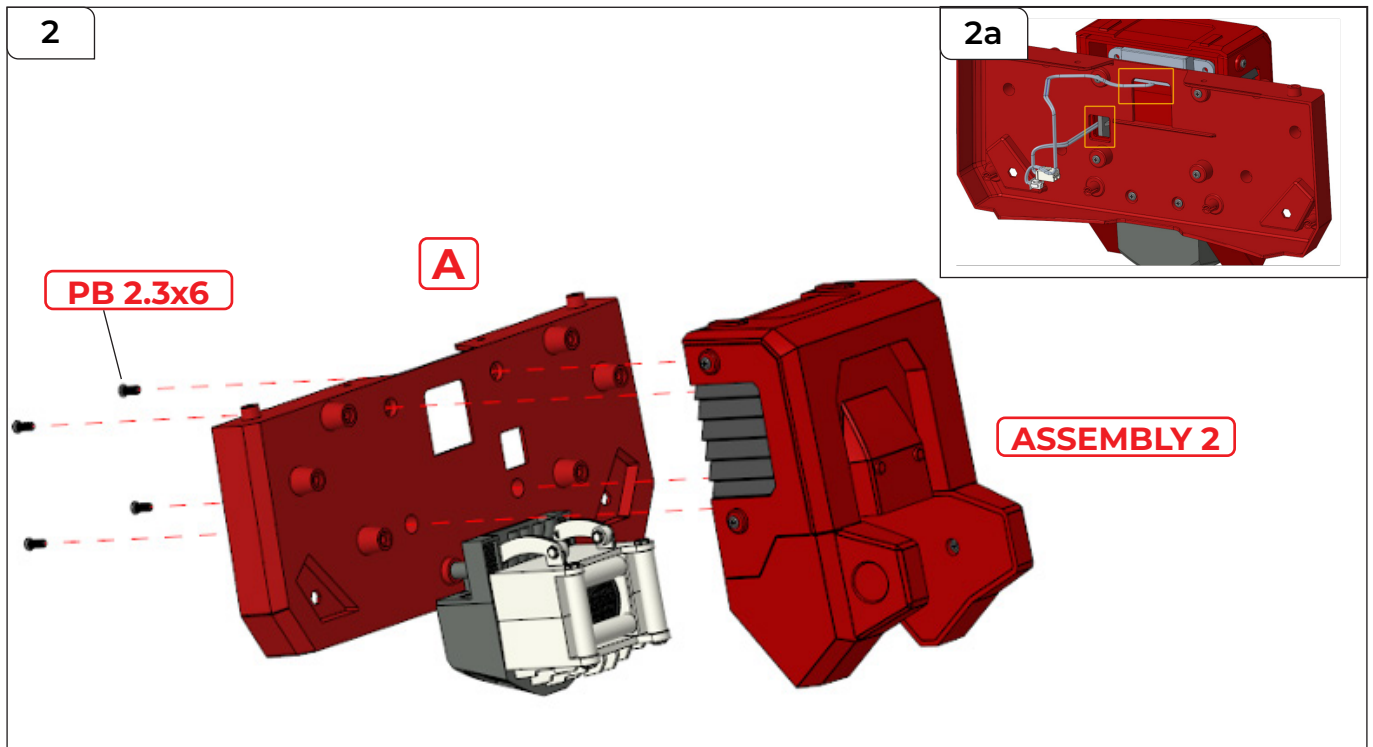

STEP 2

Retrieve ASSEMBLY 2 (page 12) and fit it to A, securing them with 4x PB 2.3x6 mm screws. Check the cables are threaded through as shown in 2a.

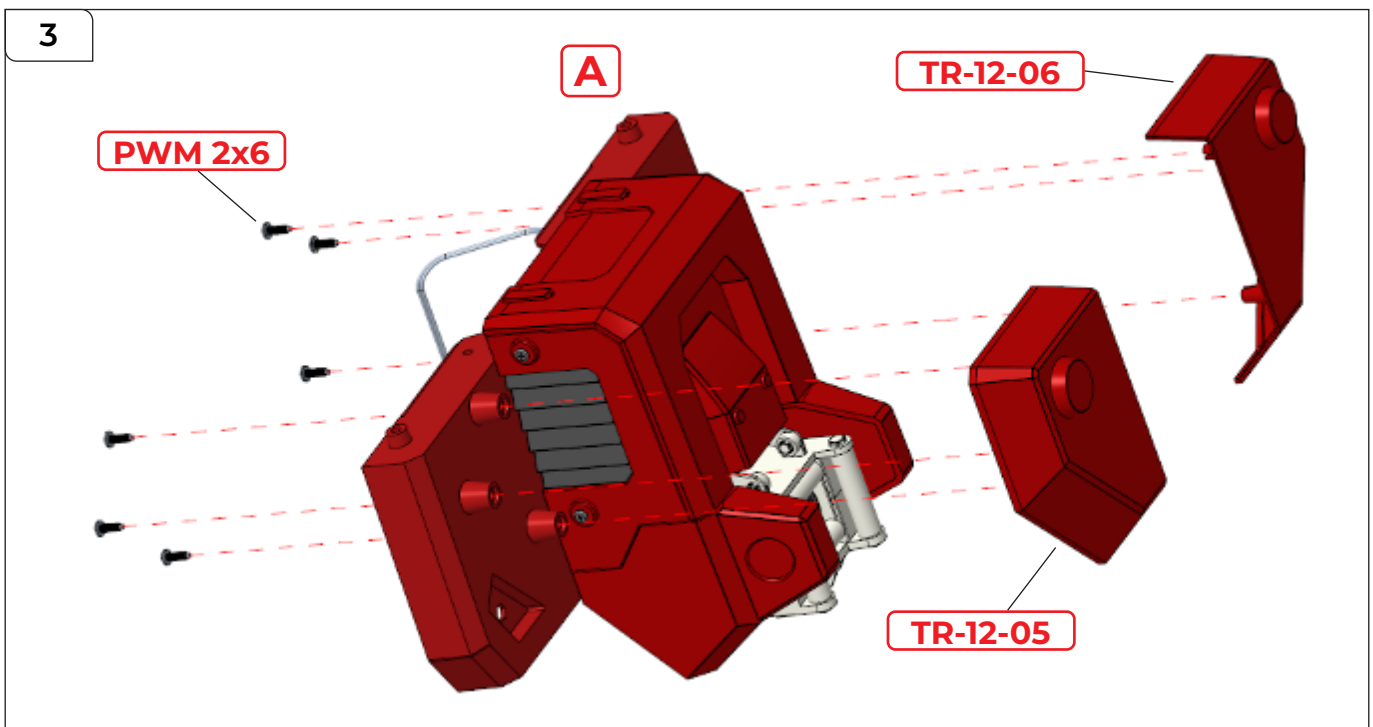

STEP 3

Fit TR-12-05 and TR-12-06 to A, securing them with 6x PWM 2x6 mm screws.

Continuing Assembly of the Back

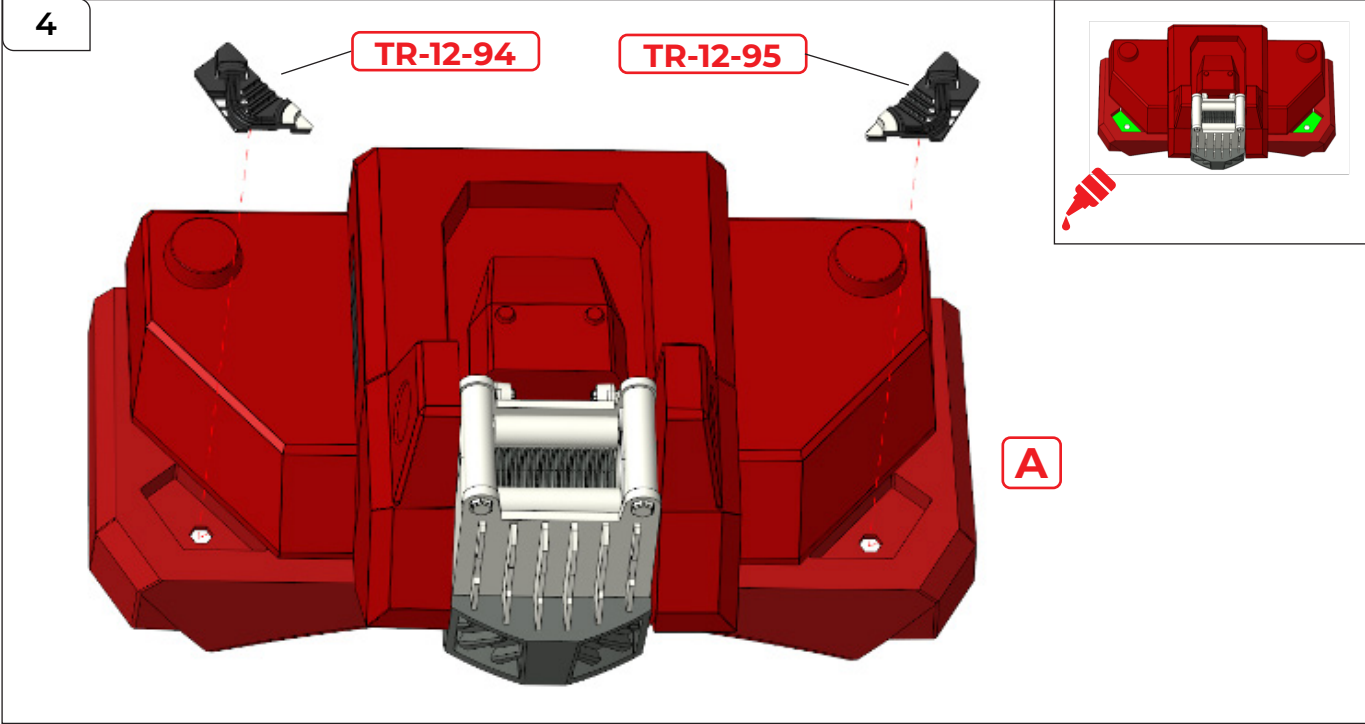

STEP 4

Apply glue to the shaped recesses and fix TR-12-94 and TR-12-95 in place.

Assembling the Chest

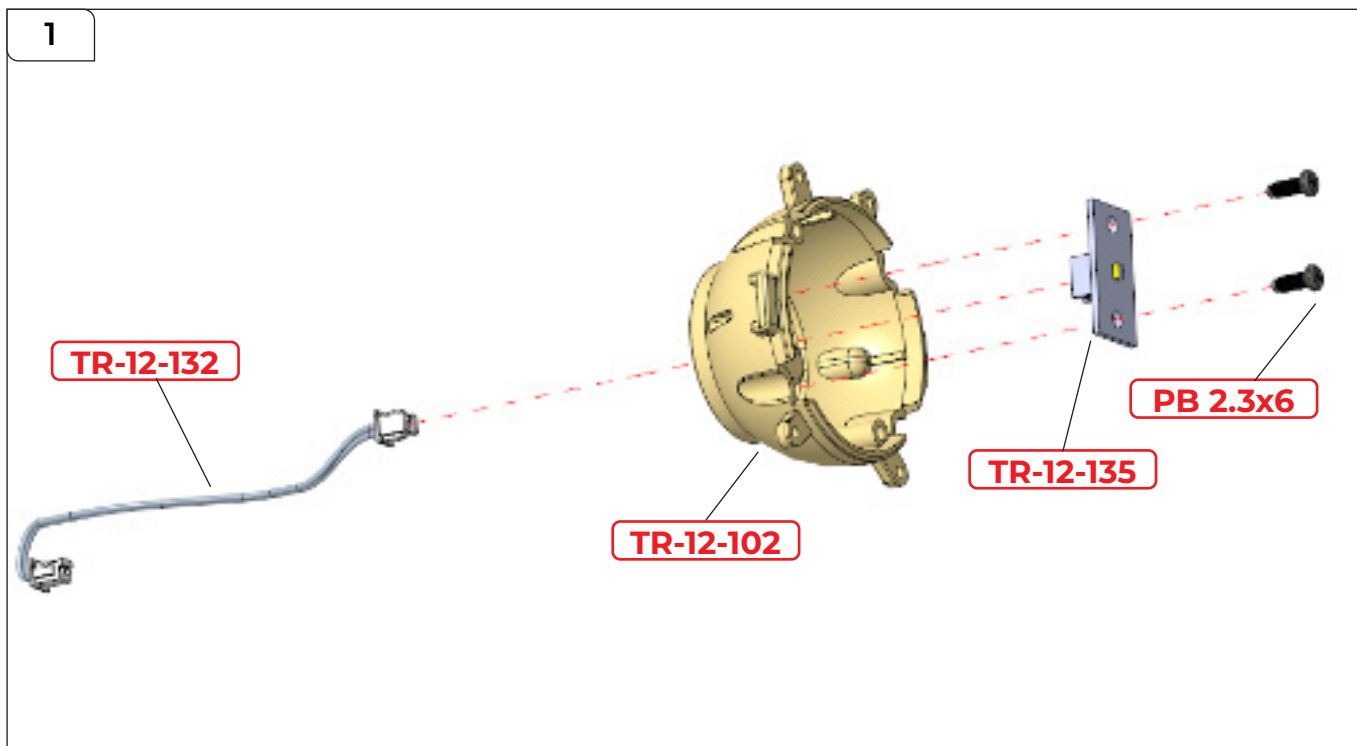

STEP 1

Fit TR-12-135 to TR-12-102 and plug in TR-12-132. Secure them with 2x PB 2.3x6 mm screws.

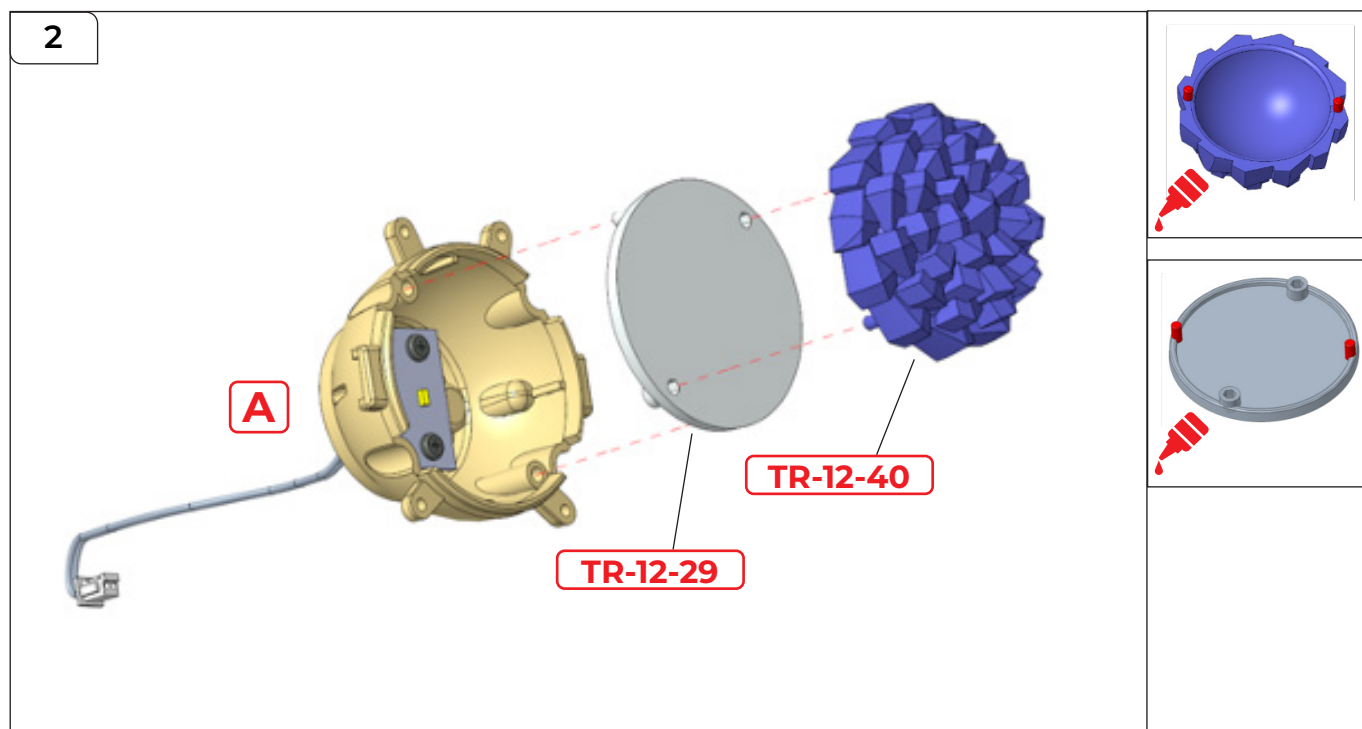

STEP 2

Apply glue to TR-12-29 and TR-12-40 then fit them to A.

Assembling the Chest

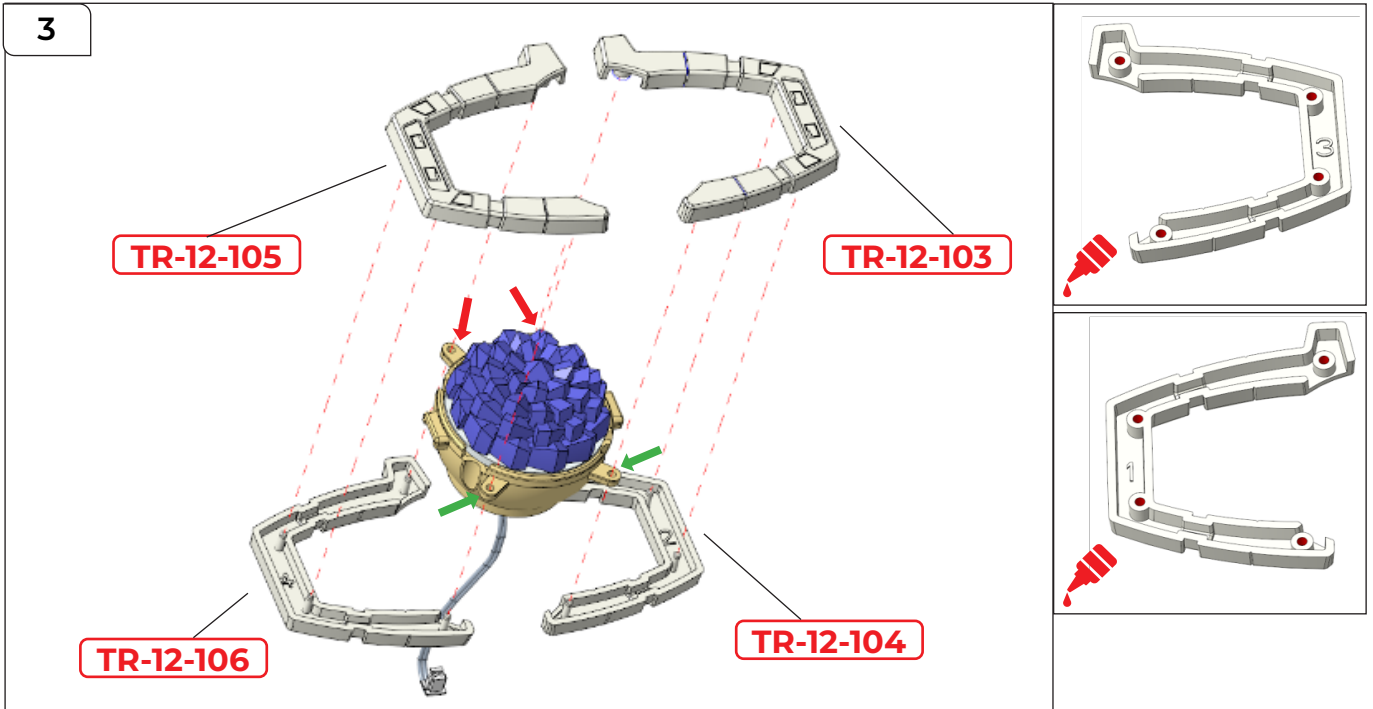

STEP 3

Glue TR-12-103 and TR-12-105, then fit them to assembly A with TR-12-106 and TR-12-104. Check you have assembly A in the correct orientation – the two fixing holes at the top (red arrows) are closer together than the two holes at the bottom (green arrows).

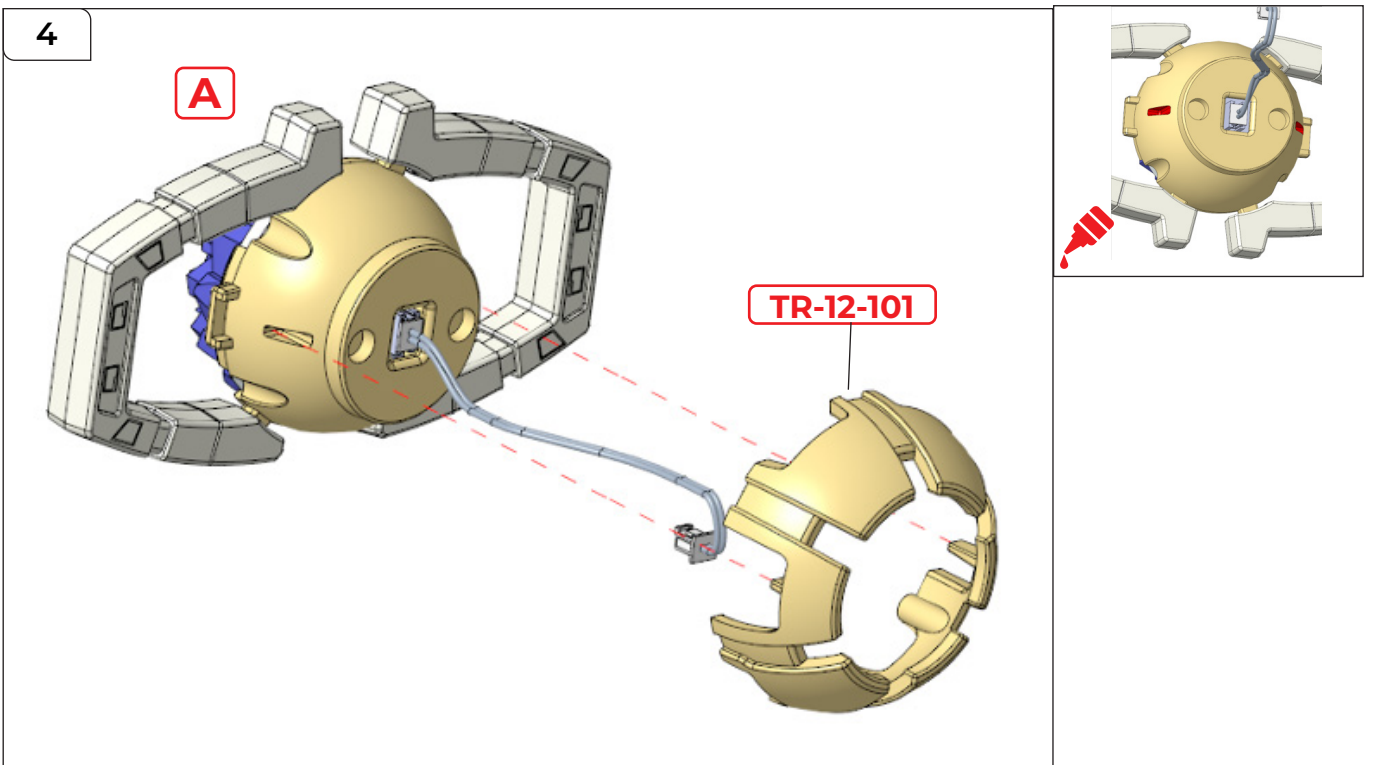

STEP 4

Test-fit part TR-12-101 onto the assembly. It should fit snug when in the correct orientation. Apply a little glue to the recessed fixing points before pushing into place.

Assembling the Chest

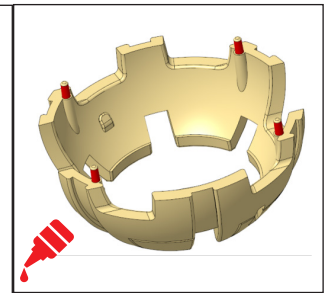
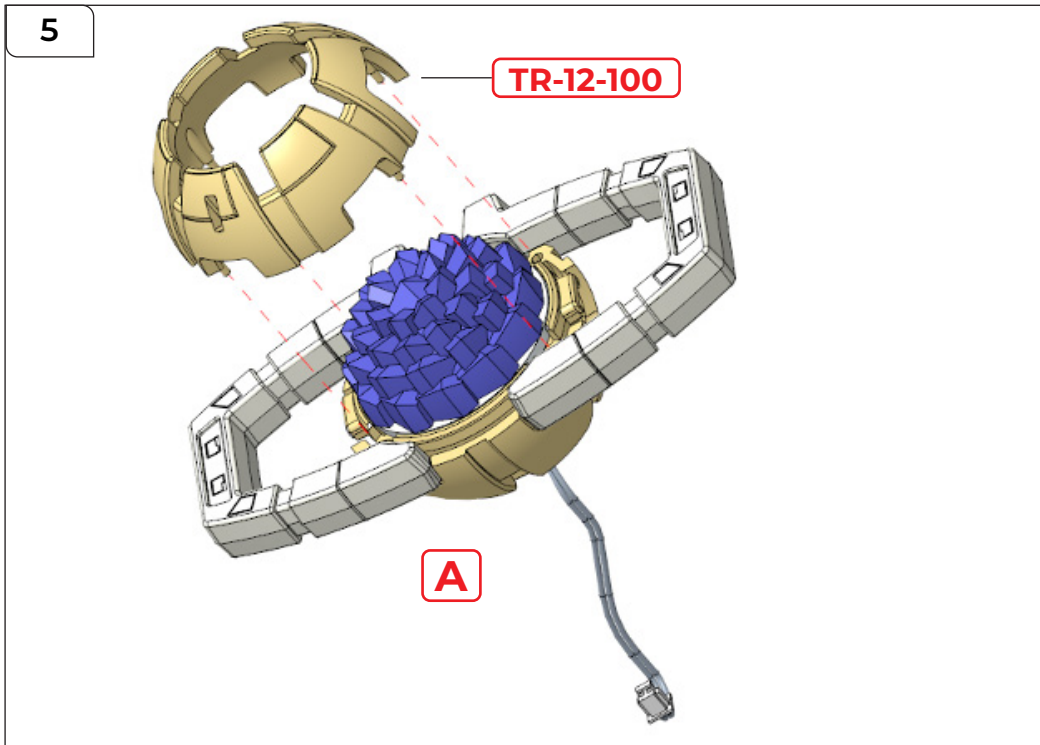

STEP 5

Test-fit part TR-12-100 to ensure a perfectly snug fit. Apply a little glue to the four pins and firmly push into place.

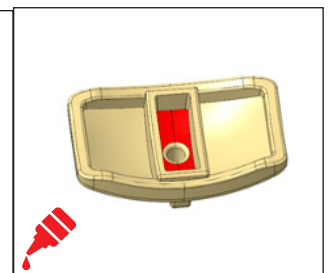
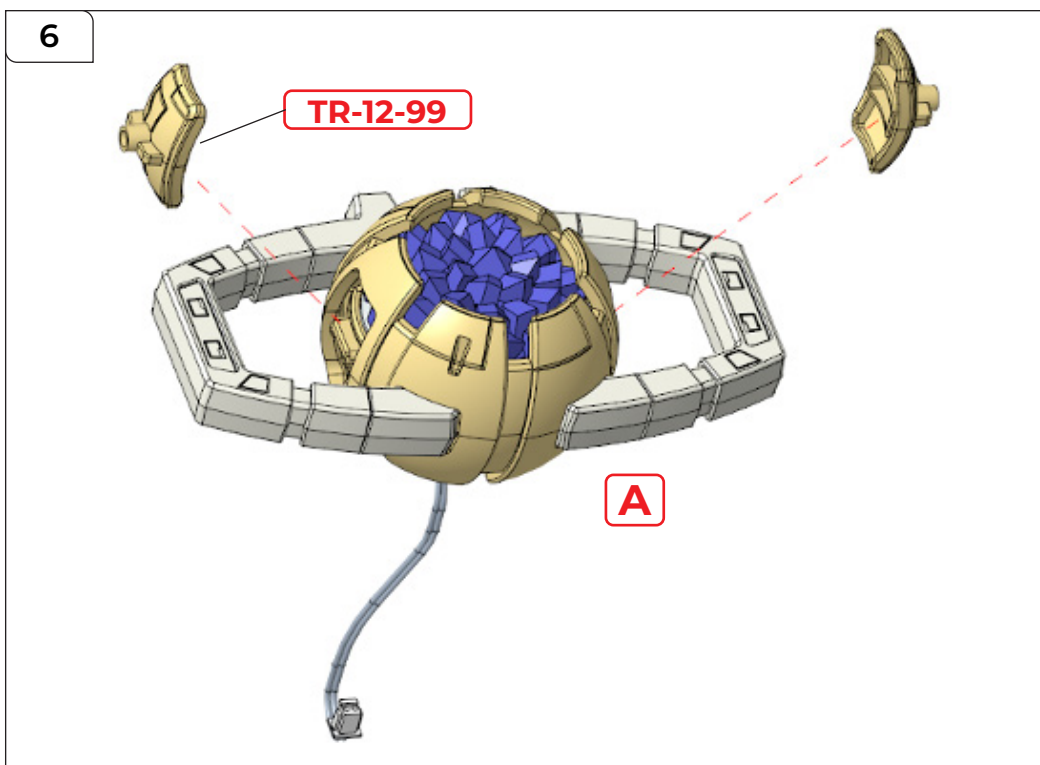

STEP 6

Glue 2x TR-12-99 and fit them to the assembly.

Assembling the Chest

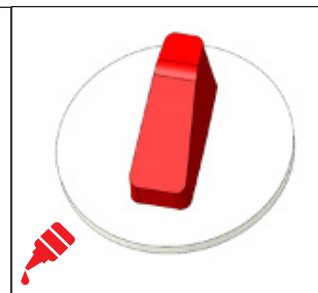
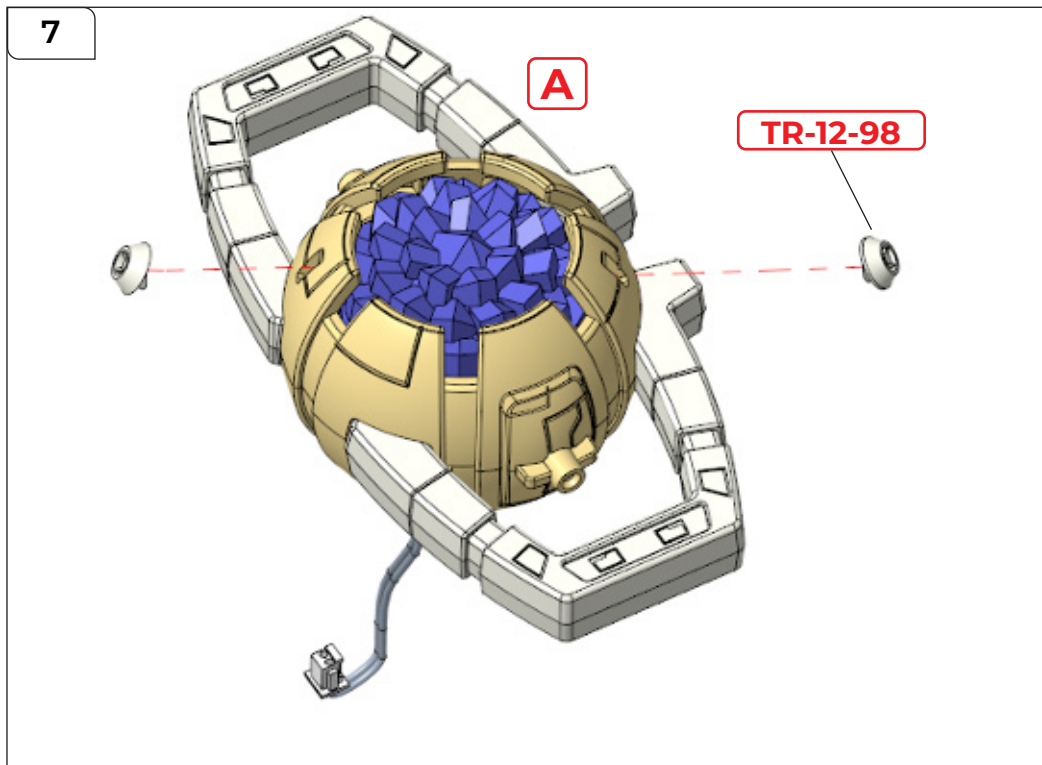

STEP 7

Glue 2x TR-12-98 and fit them to the assembly.

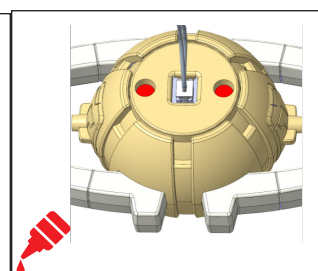
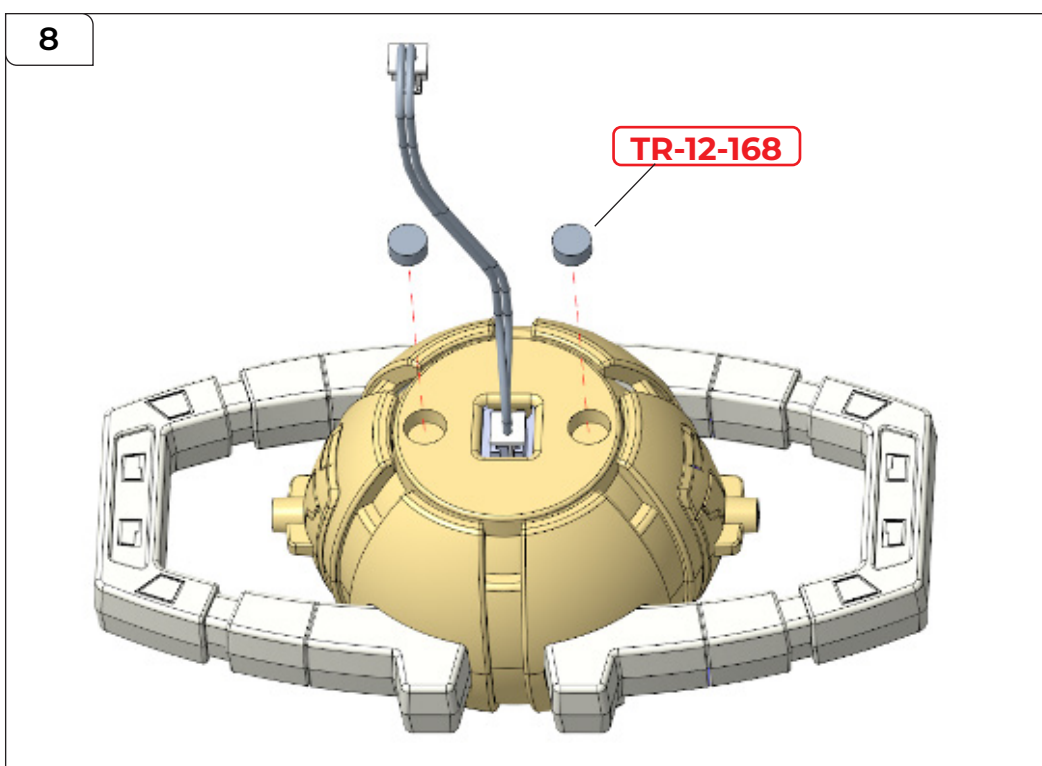

STEP 8

This time, apply a little glue to the assembly itself before fitting 2x TR-12-168.

Assembling the Chest

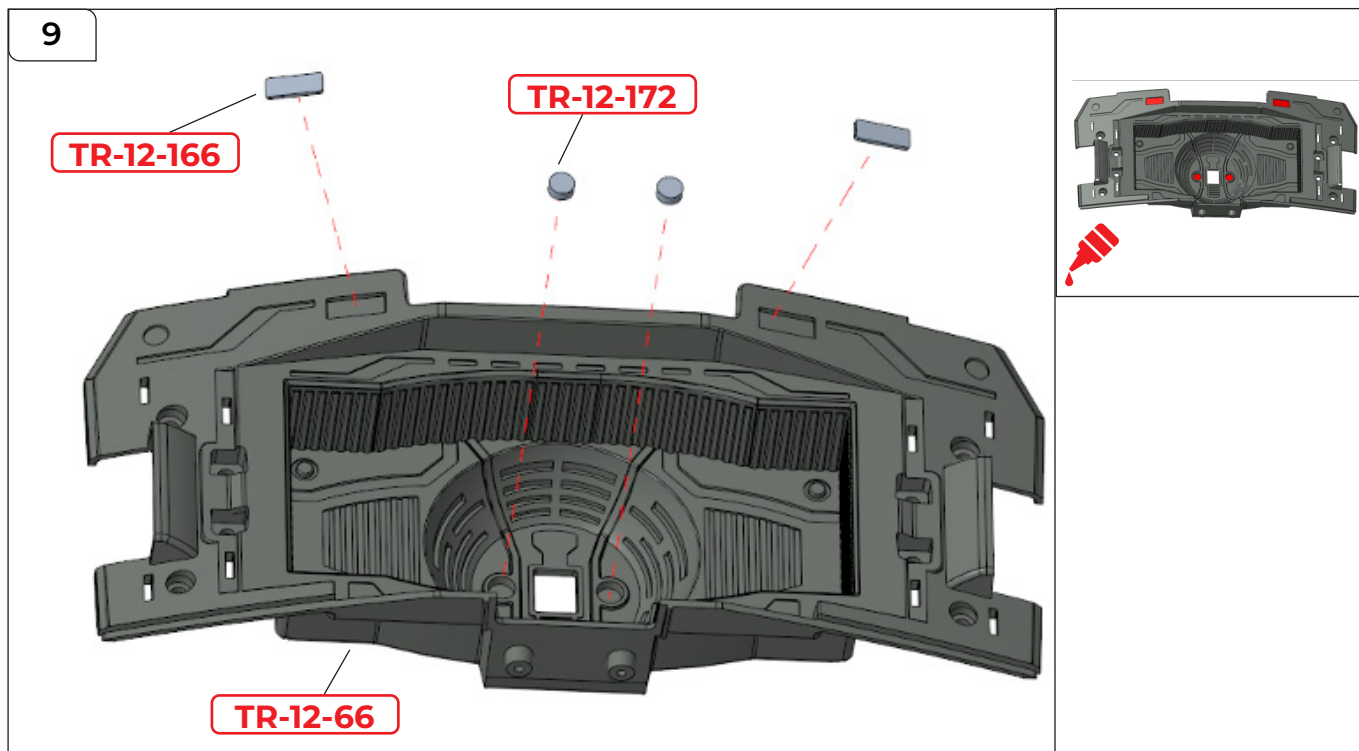

STEP 9

Take TR-12-66 and apply glue to the areas shown in red.
Fit 2x parts TR-12-166 and 2x magnets TR-12-172.

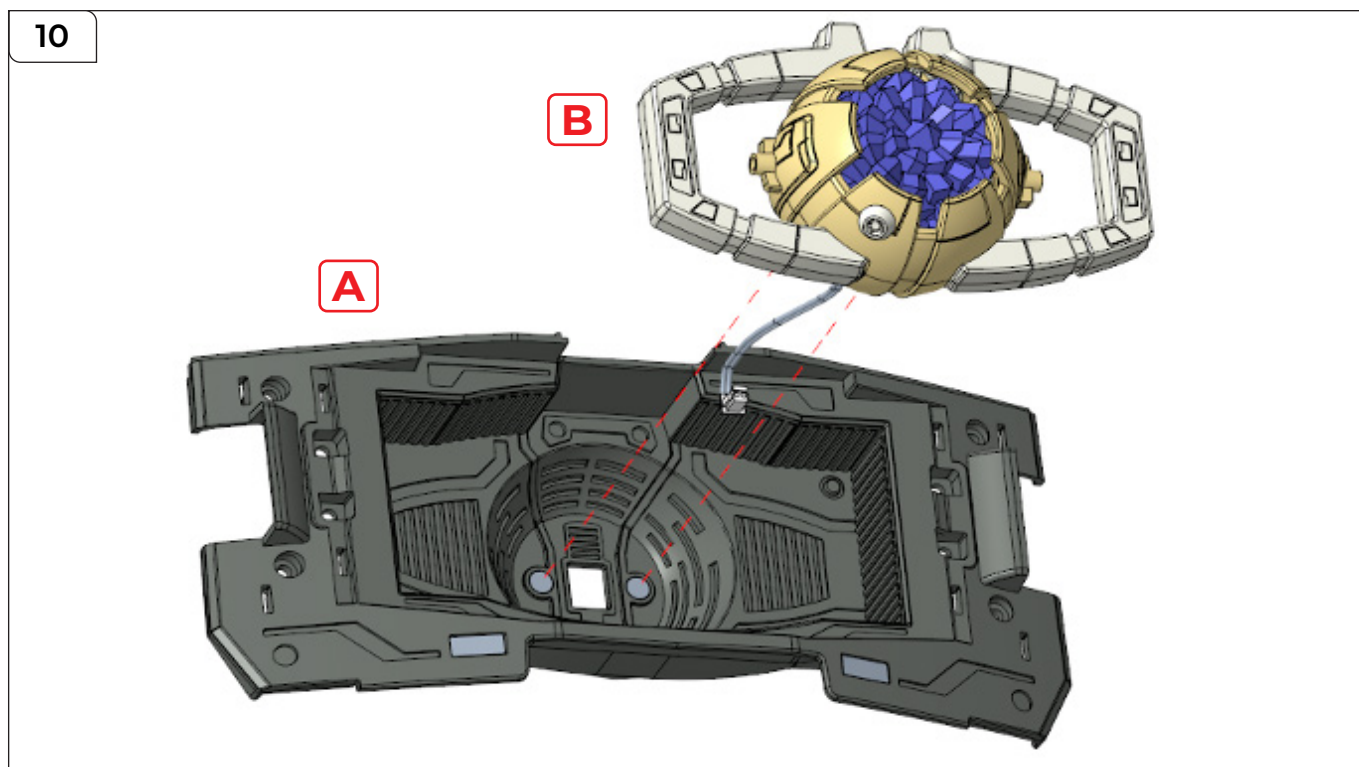

STEP 10

Fit assembly A to assembly B.

Assembling the Chest

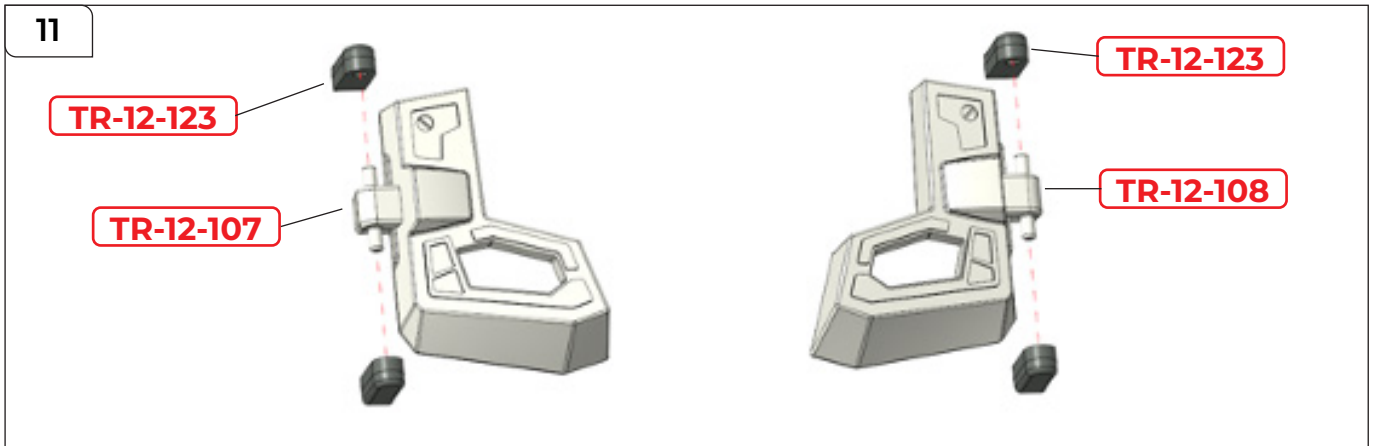

STEP 11

Take parts TR-12-107 and TR-12-108, then fit 4x TR-12-123 as shown.

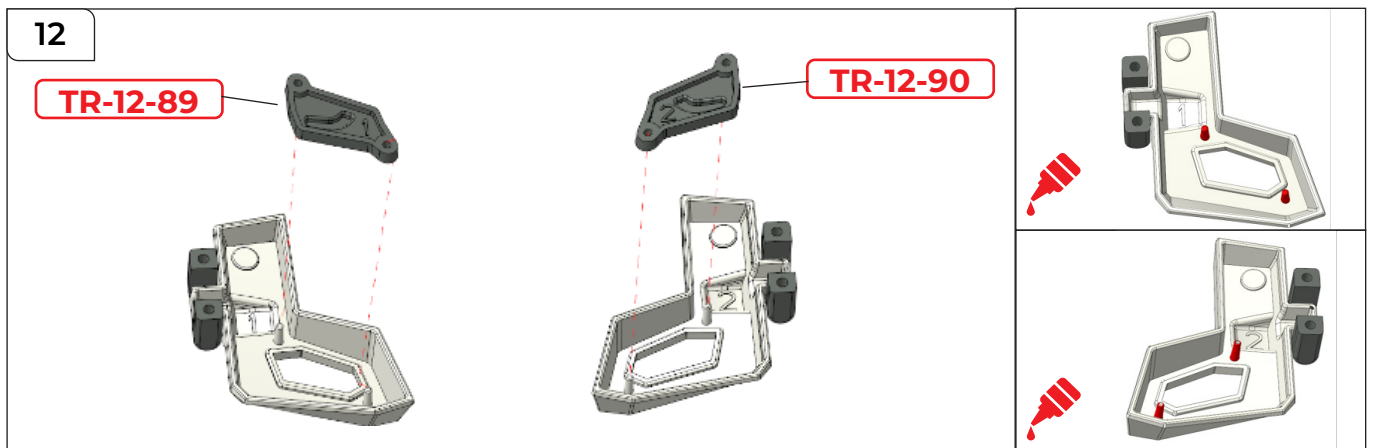

STEP 12

Apply glue to the pins shown in red before fitting parts TR-12-89 and TR-12-90.

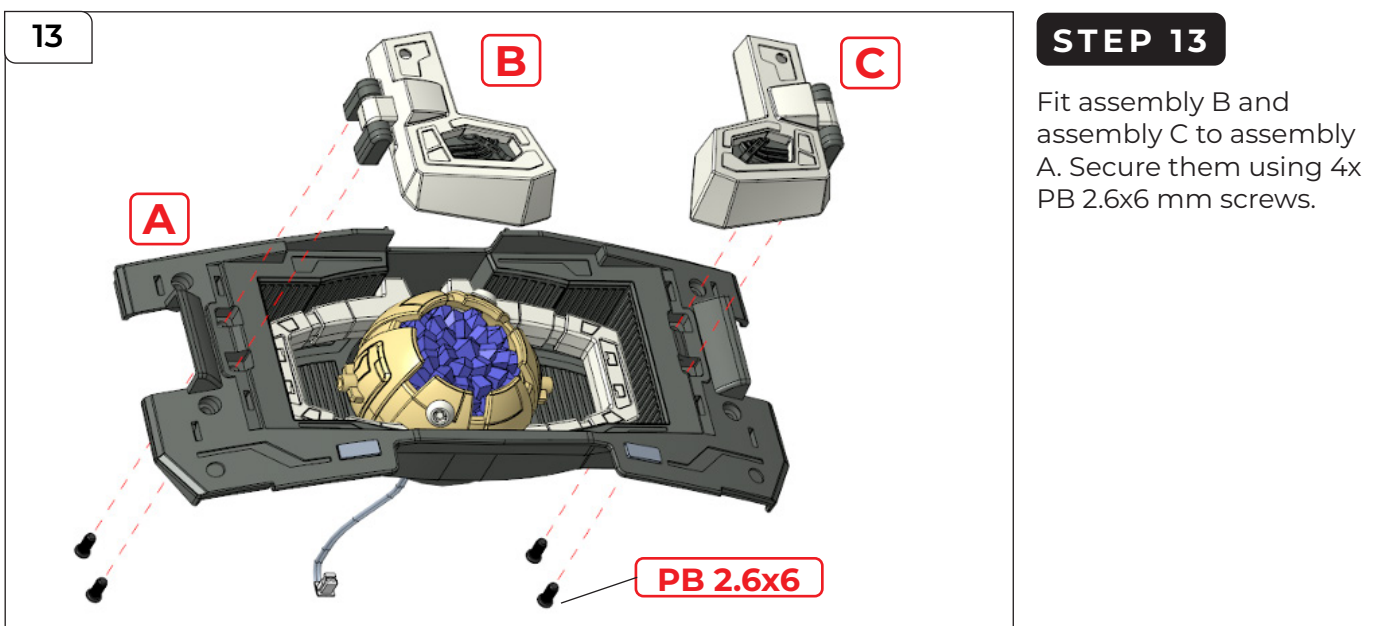

STEP 13

Fit assembly B and assembly C to assembly A. Secure them using 4x PB 2.6x6 mm screws.

Assembling the Chest

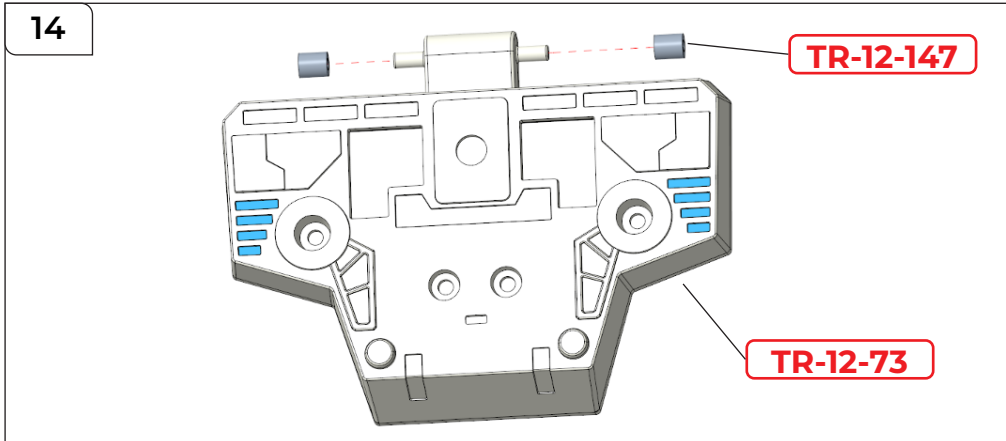

STEP 14

Fit 2x TR-12-147 (clear PVC cylinders) onto TR-12-73.

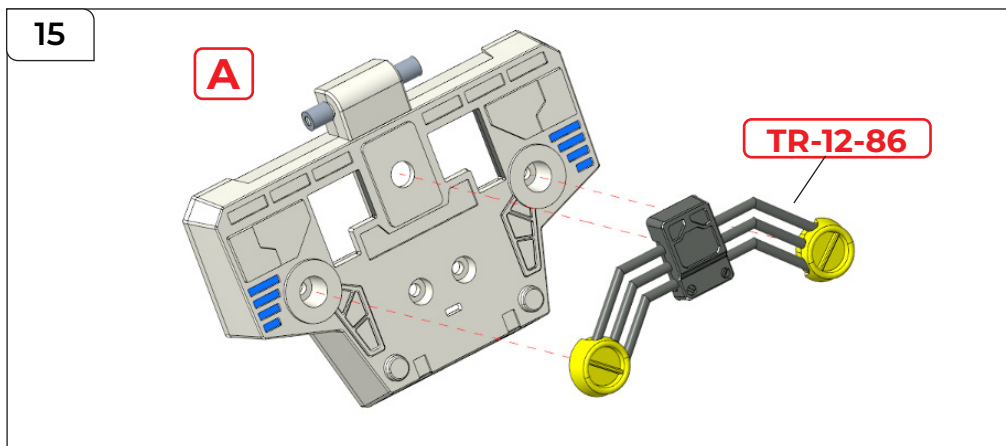

STEP 15

Fit TR-12-86 into place.

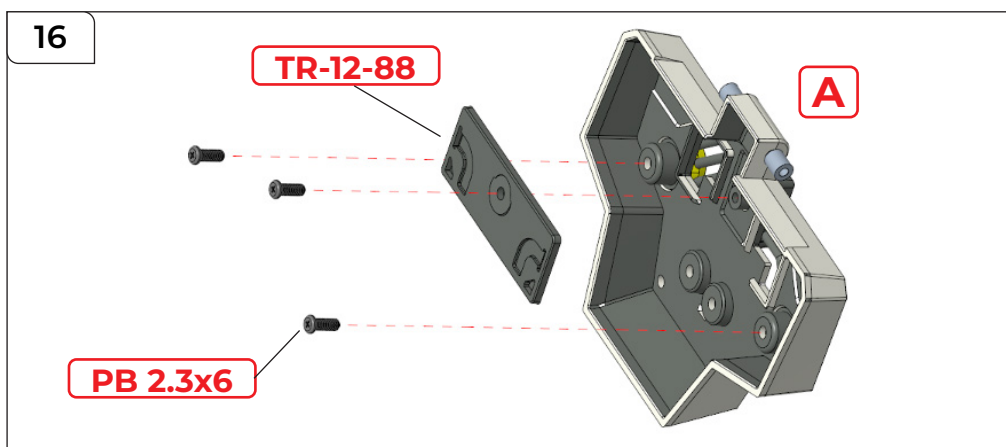

STEP 16

Fit TR-12-88 to the reverse side and secure using 3x PB 2.3x6 mm screws.

Assembling the Chest

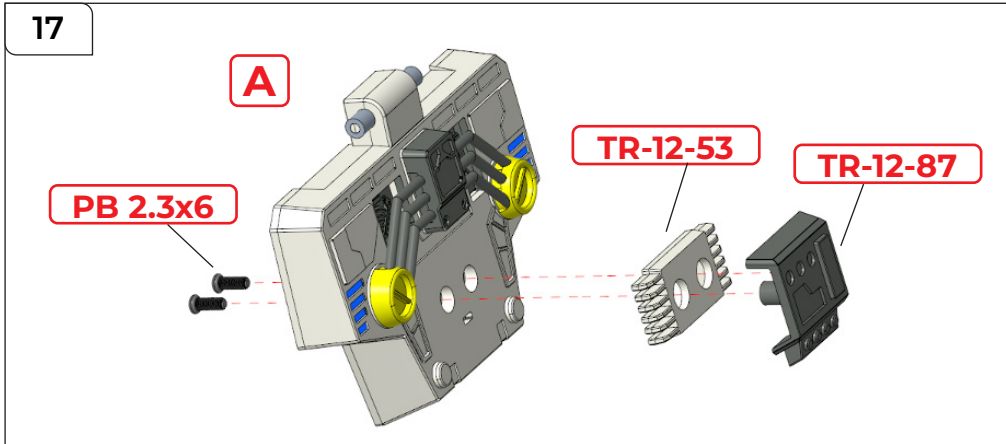

STEP 17

Fit TR-12-87 to TR-12-53, then place them onto the assembly, securing from the reverse side using 2x PB 2.3x6 mm screws.

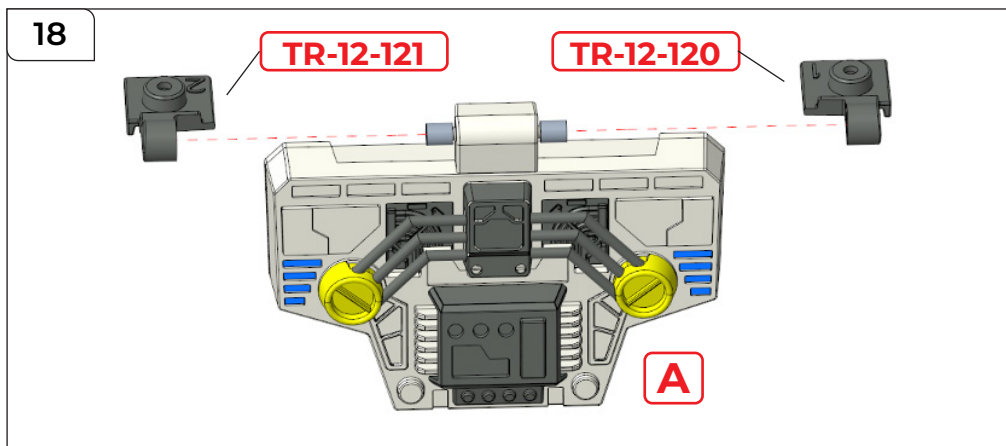

STEP 18

Fit TR-12-121 and TR-12-120 to the assembly in the orientation show. See the next step.

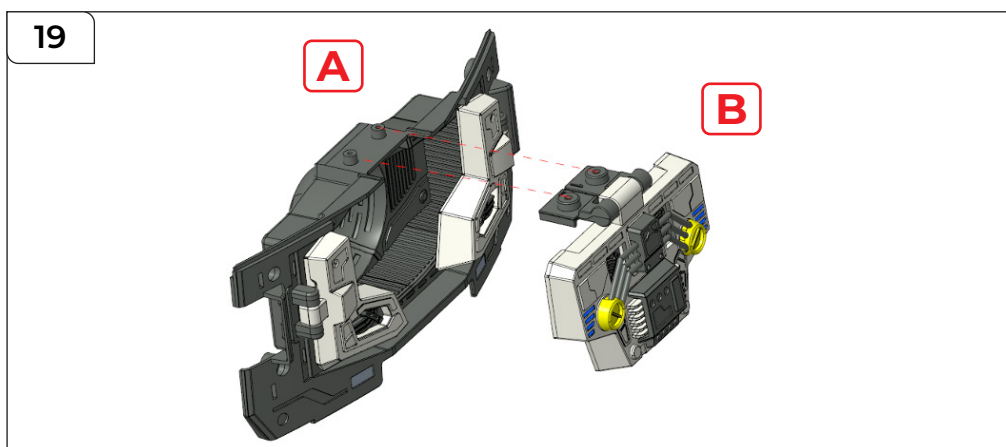

STEP 19

Fit assembly B to assembly A.

Assembling the Chest

20

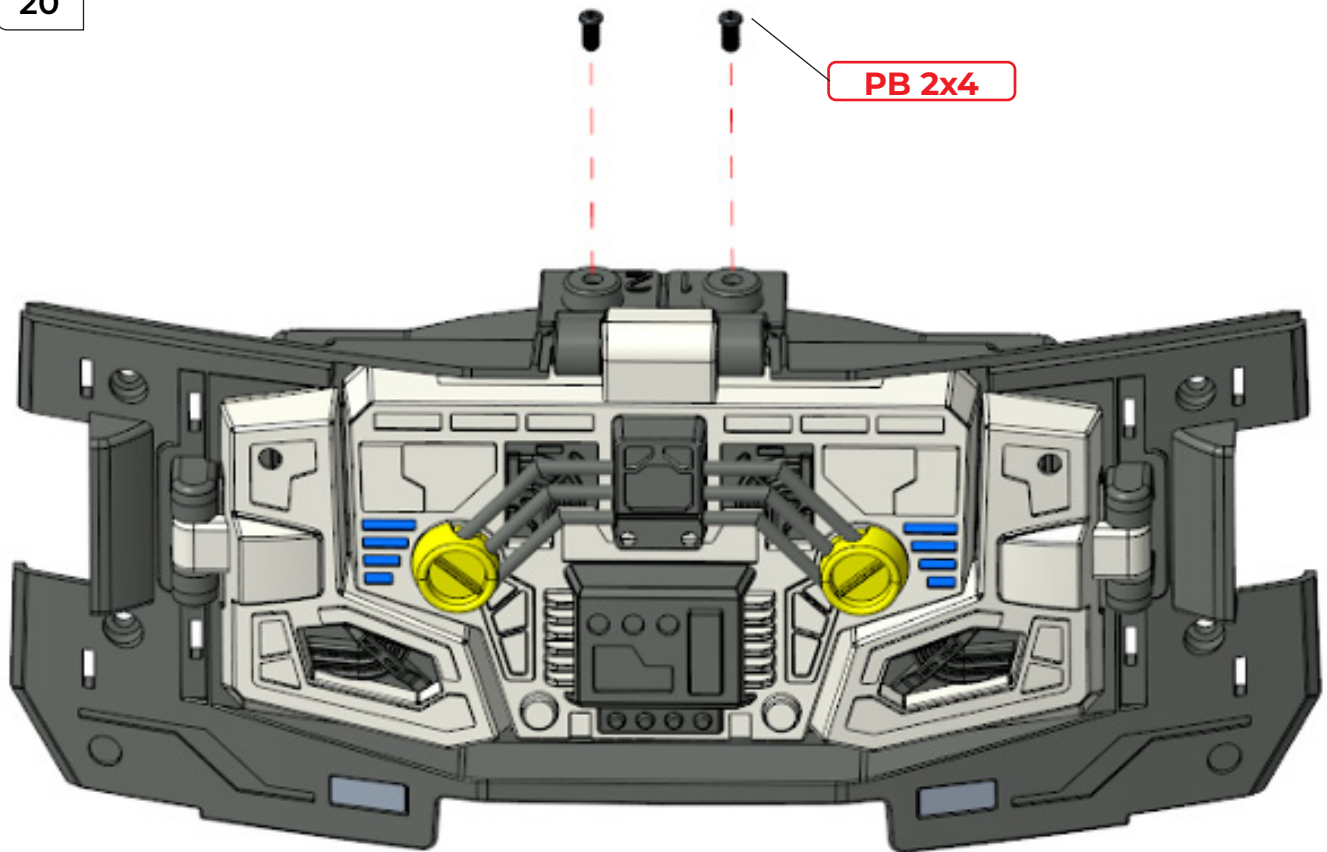

STEP 20

Secure assembly B using 2x PB 2x4 mm screws. The chest is now complete.

Attaching the Left Arm and Chest

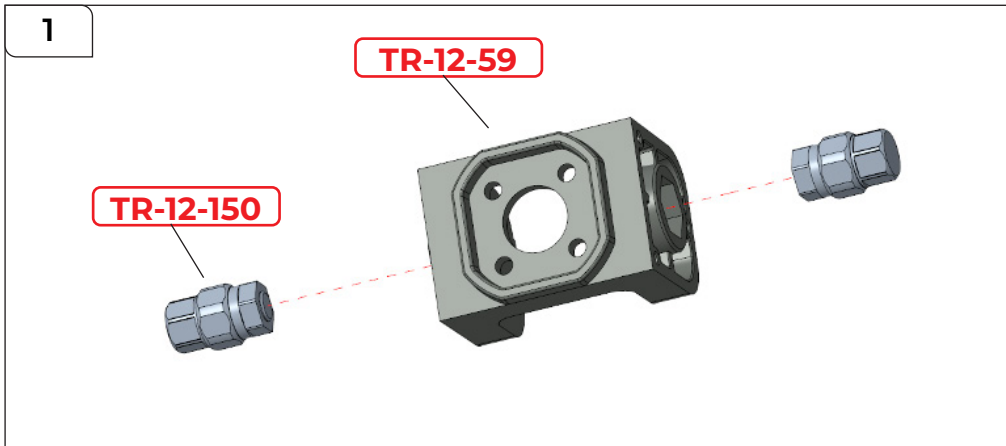

STEP 1

Fit 2x TR-12-150 to TR-12-59.

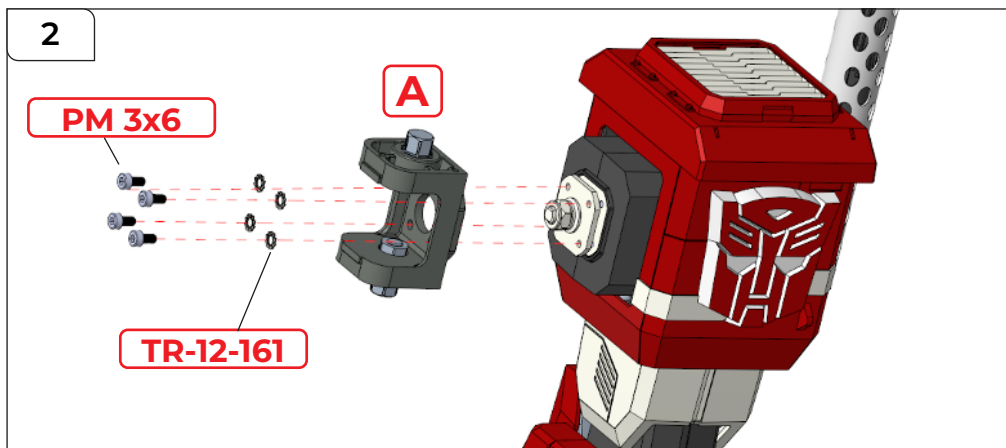

STEP 2

Fit assembly A to the arm. Thread TR-12-161 onto 4x PM 3x6 screws and use them to secure parts together.

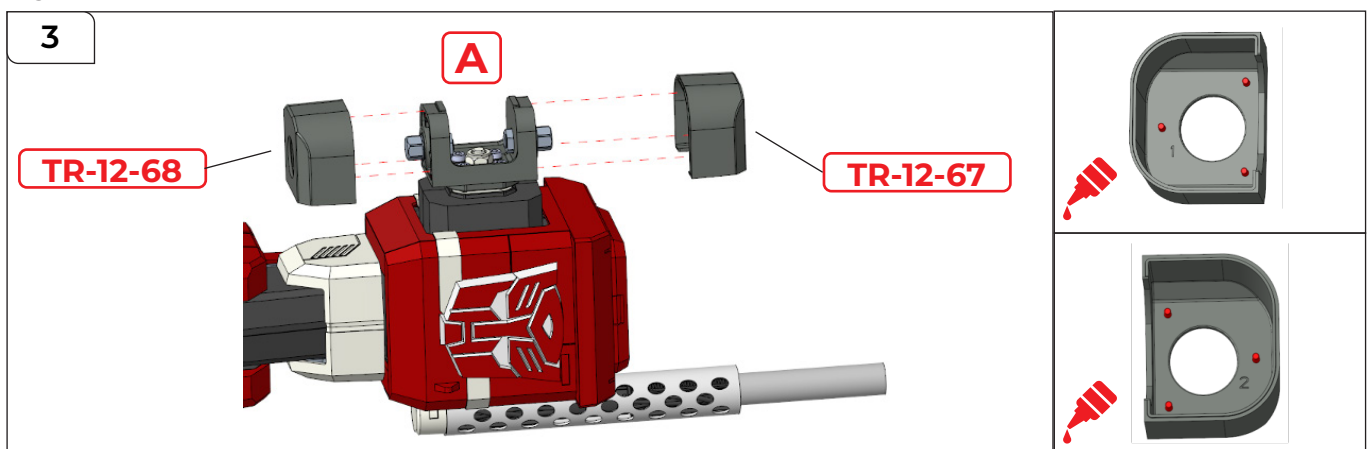

STEP 3

Glue the pins on TR-12-67 and TR-12-68, then attach them to the assembly.

Attaching the Left Arm and Chest

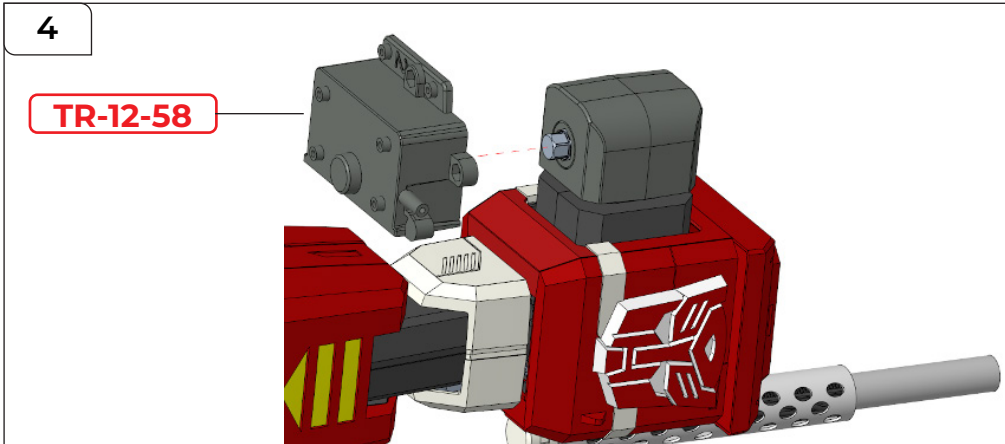

STEP 4

Fit TR-12-58.

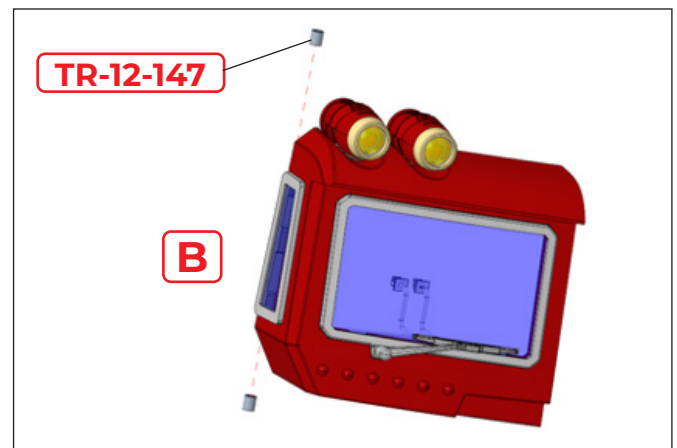
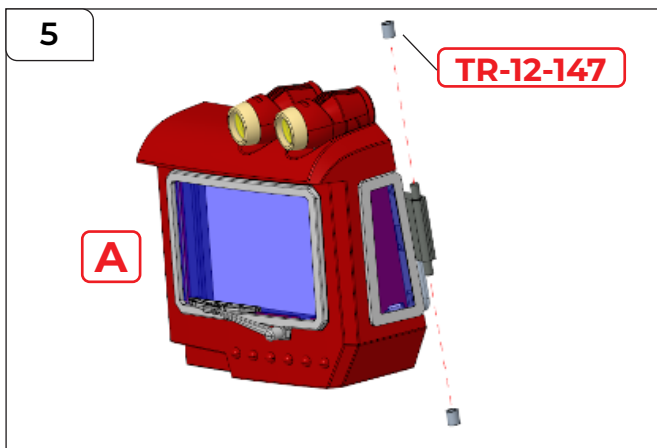

STEP 5

Fit 4x TR-12-147 to the hinges of the chest windows from pack 1.

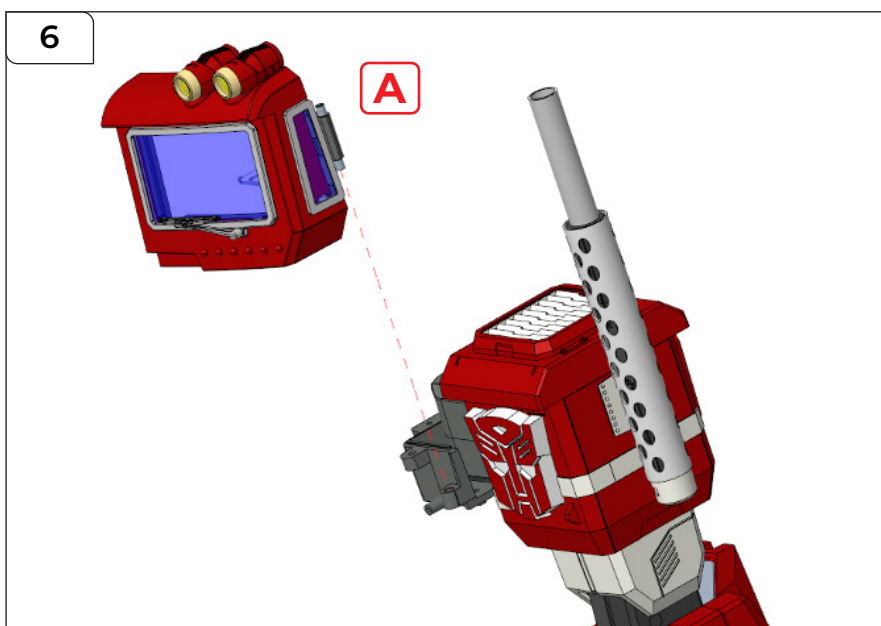

STEP 6

Fit the left door hinge to the left arm. If the hinge is difficult to fit, try removing part 147 and place it into the hole instead.

Attaching the Left Arm and Chest

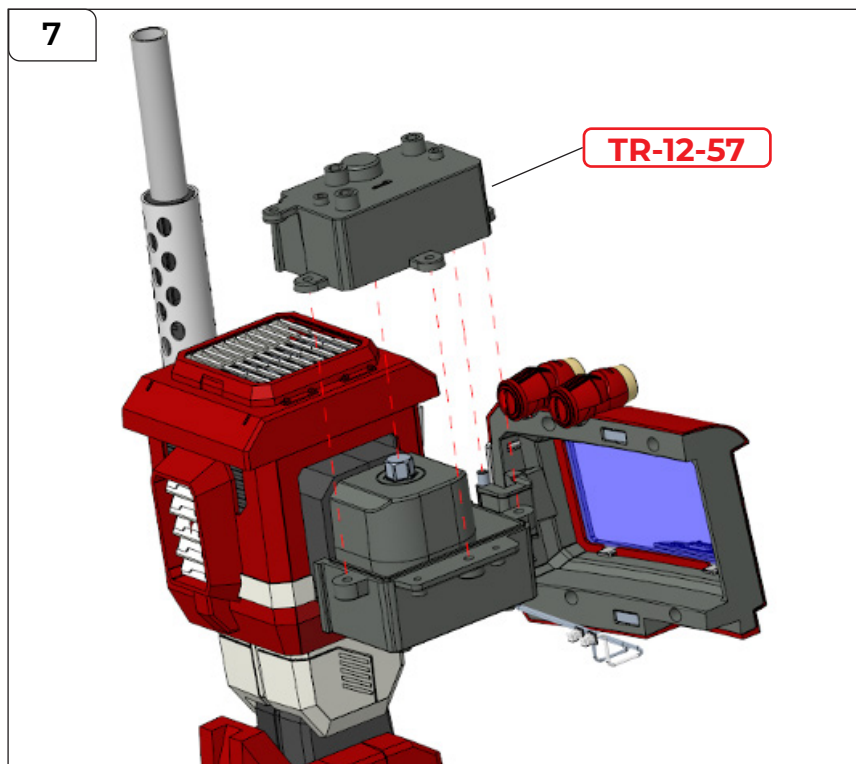

STEP 7

Fit TR-12-57 into position, aligning the screw holes.

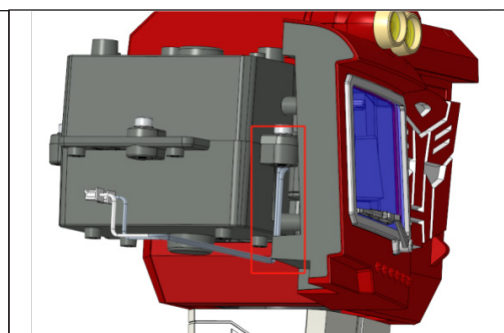
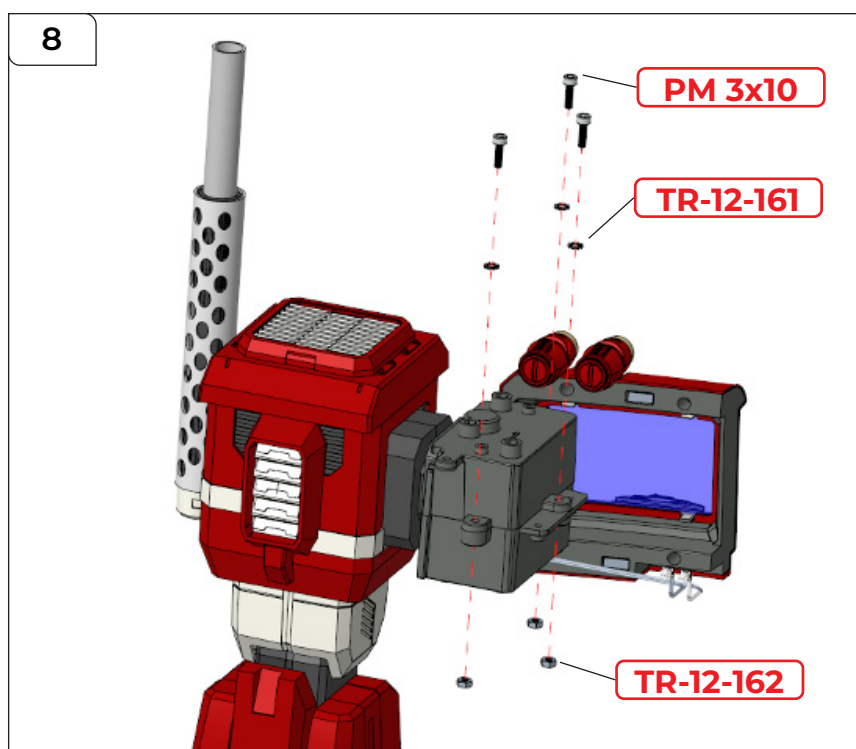

STEP 8

Check the cables are not trapped, then place a TR-12-162 (nut 3) below each screw hole. Thread TR-12-161 onto a PM 3x10 mm screw, then drive it through the hole and into the nut. Repeat as shown.

Attaching the Left Arm and Chest

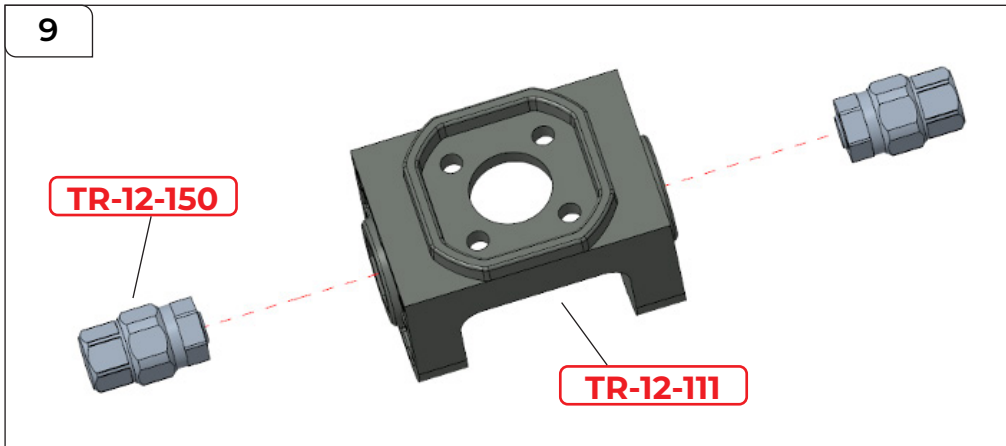

STEP 9

You'll now repeat these steps to attach the right chest window to the right arm. Start by fitting 2x TR-12-150 to TR-12-111.

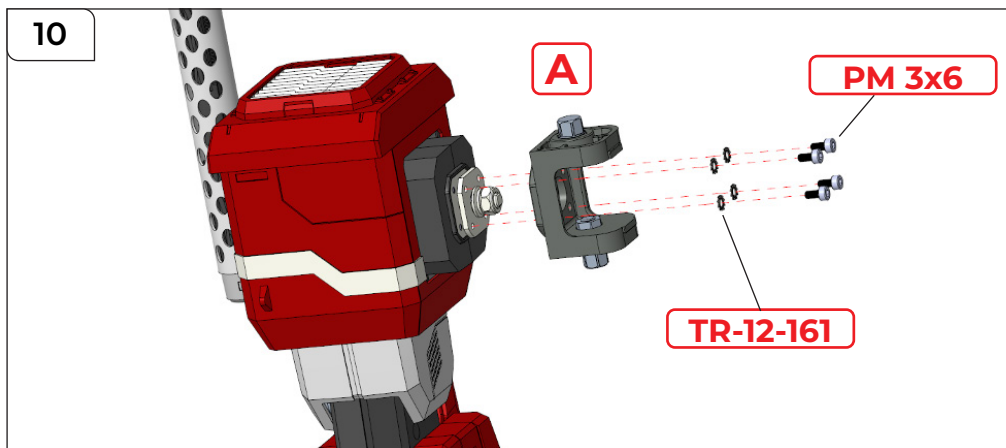

STEP 10

Fit the assembly to the right arm, securing it in place with 4 x TR-12-161 and 4x PM 3x6 screws.

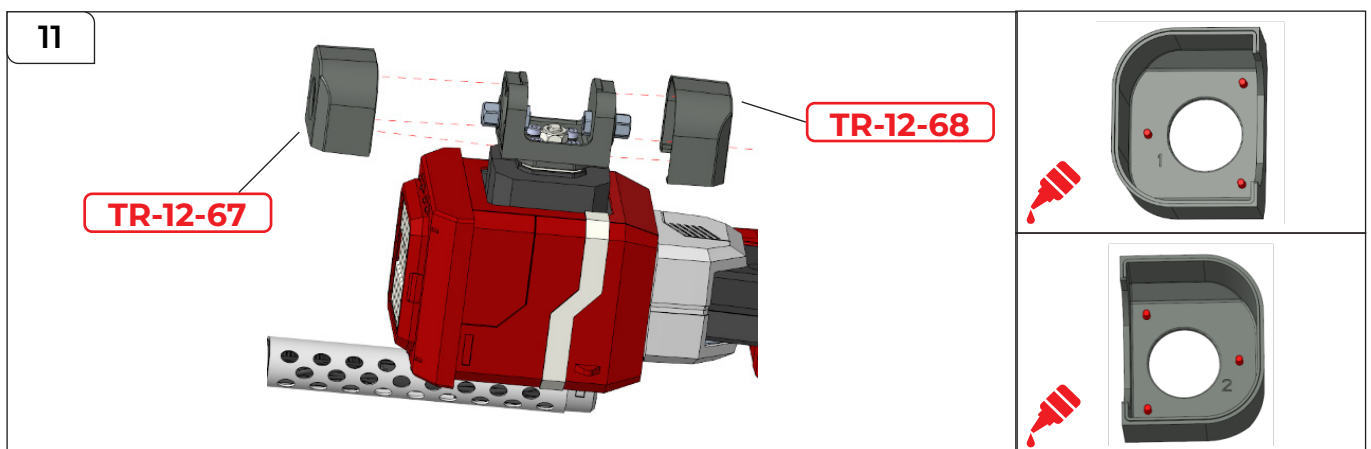

STEP 11

Glue the pins on TR-12-67 and TR-12-68, then fit them to the assembly.

Attaching the Left Arm and Chest

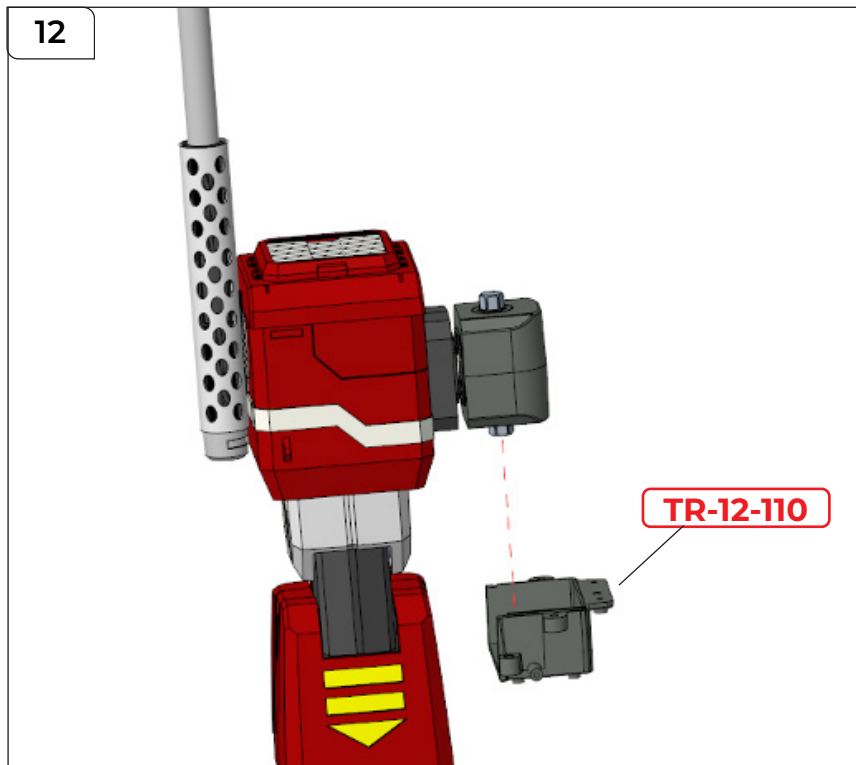

STEP 12

Fit TR-12-110.

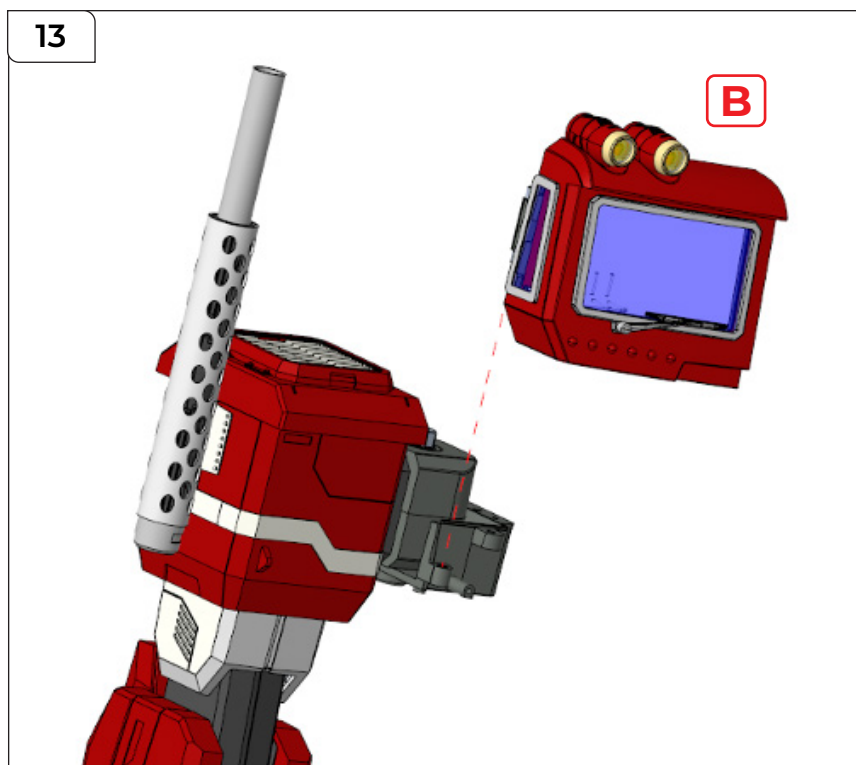

STEP 13

Attach the right chest window by its hinge.

Attaching the Left Arm and Chest

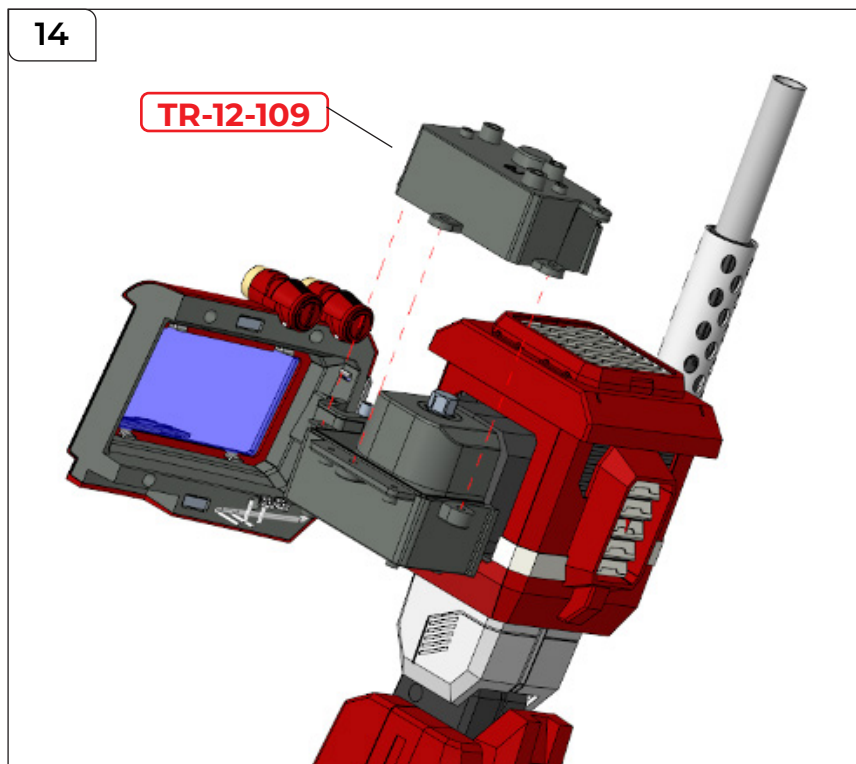

STEP 14

Fit TR-12-109

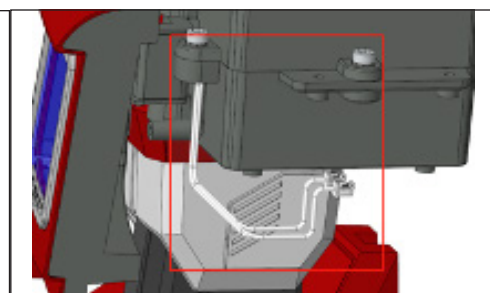
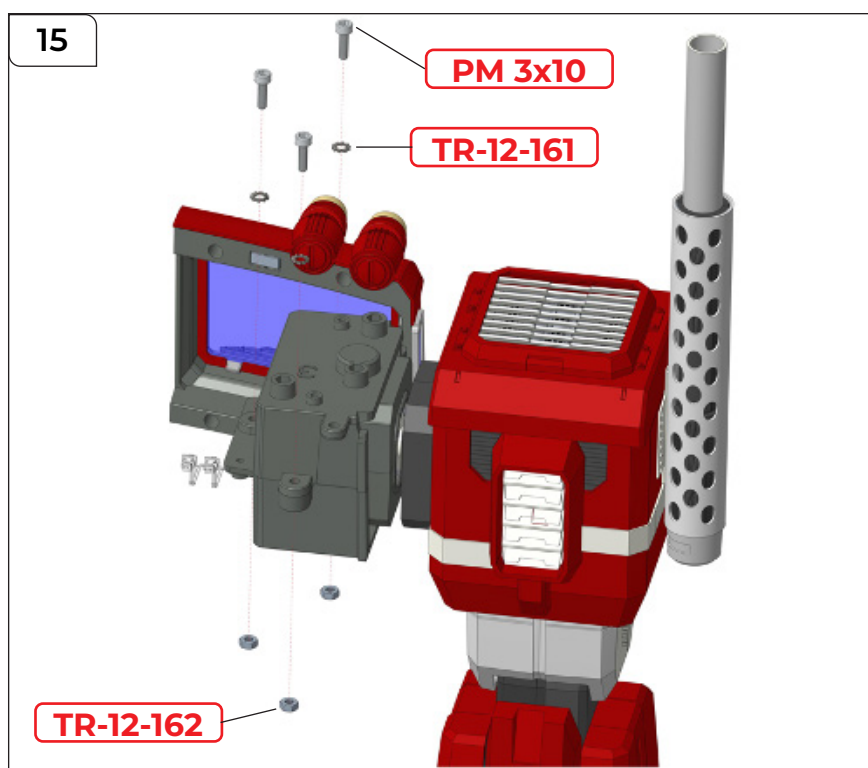

STEP 15

Check the cable isn't trapped, then secure the parts together using 3x TR-12-162 (nut 3) below each hole, and 3x TR-12-161 threaded onto 3x PM 3x10 screws.

Labeling the Electrical Components

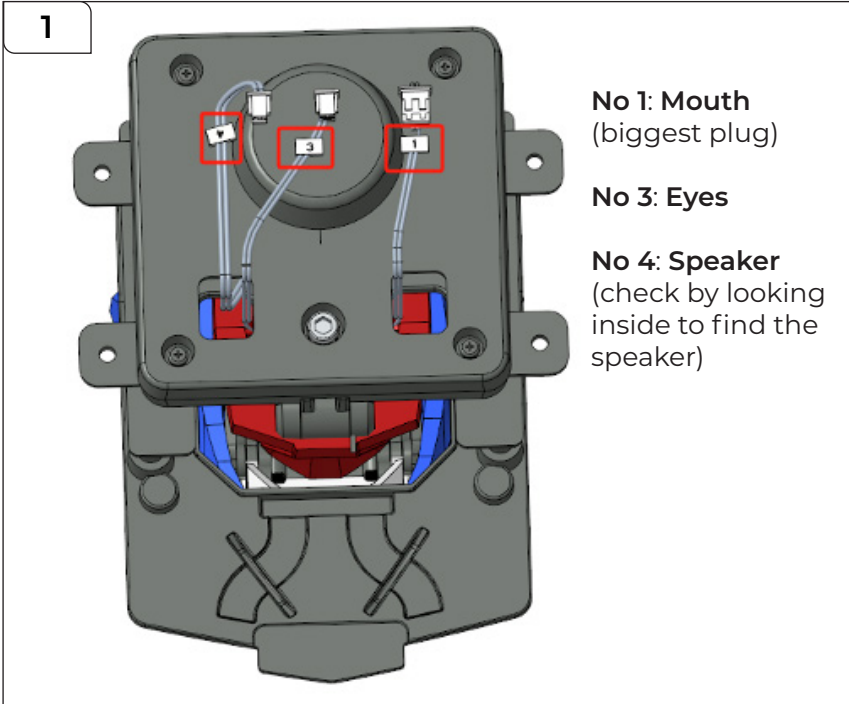

| | | | |
|---|---|----|----|
| 1 | 1 | 7 | 7 |
| 2 | 2 | 8 | 8 |
| 3 | 3 | 9 | 9 |
| 4 | 4 | 10 | 10 |
| 5 | 5 | 11 | 11 |
| 6 | 6 | 12 | 12 |

TR-12-163

STEP 1

Next you'll identify each of the electrical cables by placing a numbered sticker on each one, starting with the head assembly completed at the beginning of this pack. Take the sticker sheet TR-12-163 and apply sticker numbers '1', '3' and '4' to the cable line as indicated.

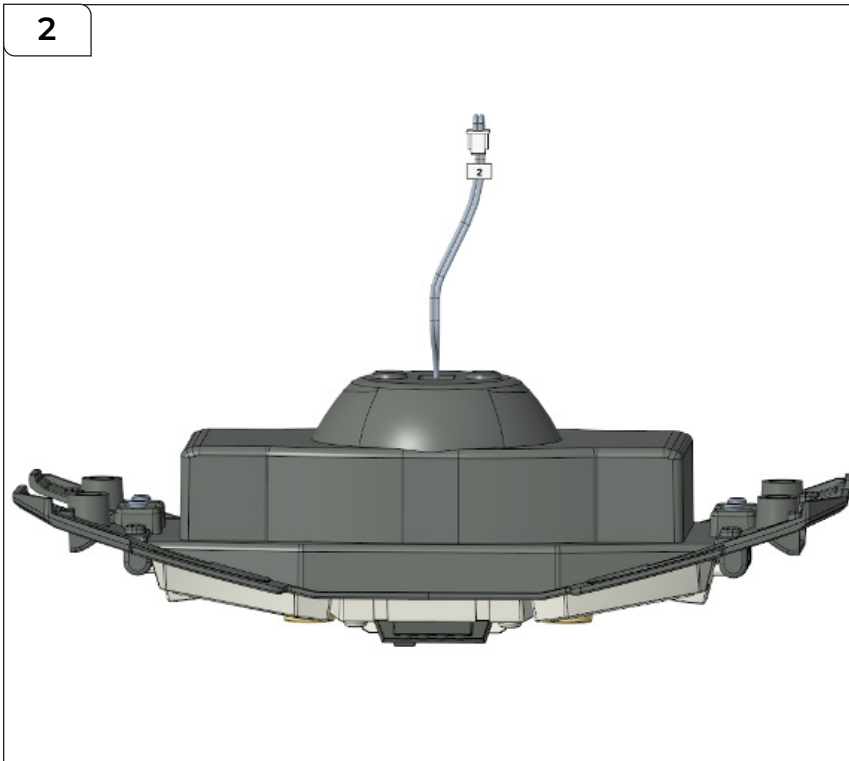

| | | | |
|---|---|----|----|
| 1 | 1 | 7 | 7 |
| 2 | 2 | 8 | 8 |
| 3 | 3 | 9 | 9 |
| 4 | 4 | 10 | 10 |
| 5 | 5 | 11 | 11 |
| 6 | 6 | 12 | 12 |

TR-12-163

STEP 2

Remove sticker number "2" from the sheet and place it on the cable coming from the Matrix.

Labeling the Electrical Components

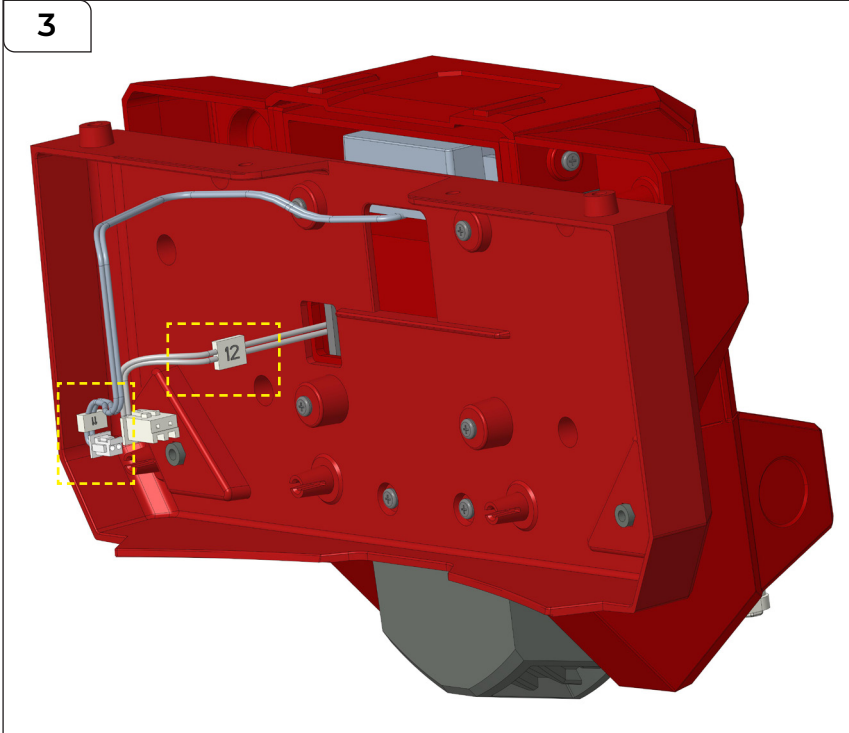

| | | | |
|---|---|----|----|
| 1 | 1 | 7 | 7 |
| 2 | 2 | 8 | 8 |
| 3 | 3 | 9 | 9 |
| 4 | 4 | 10 | 10 |
| 5 | 5 | 11 | 11 |
| 6 | 6 | 12 | 12 |

TR-12-163

STEP 3

Remove sticker numbers "11" and "12" from the sheet and place them on the cables coming from the Back

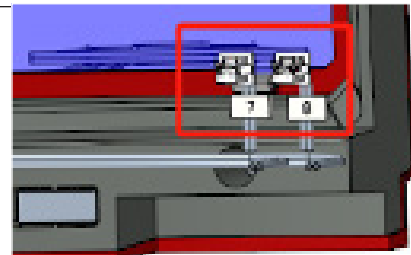
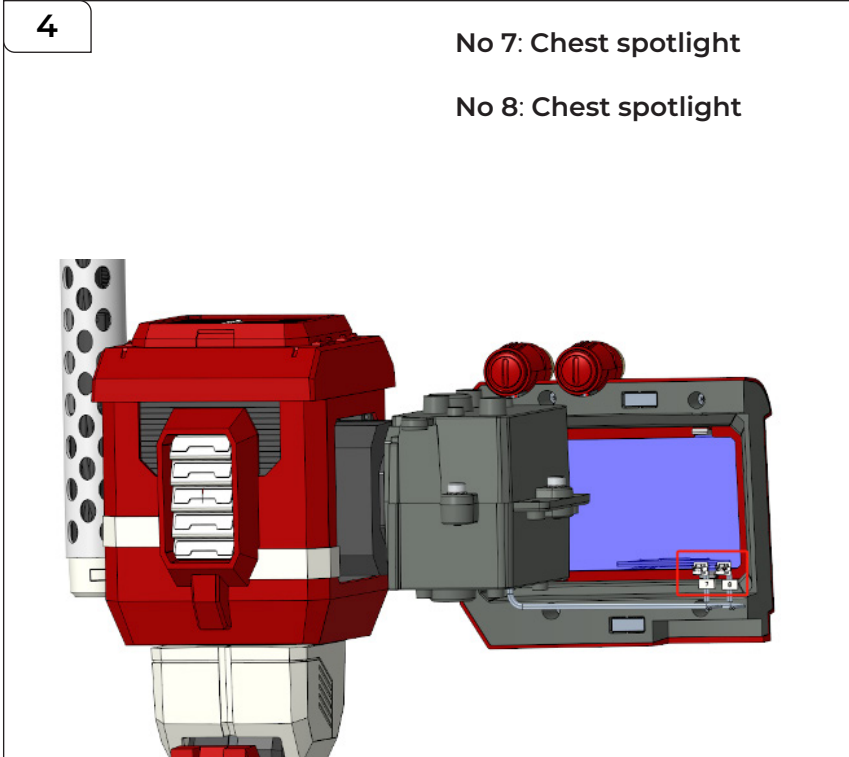

| | | | |
|---|---|----|----|
| 1 | 1 | 7 | 7 |
| 2 | 2 | 8 | 8 |
| 3 | 3 | 9 | 9 |
| 4 | 4 | 10 | 10 |
| 5 | 5 | 11 | 11 |
| 6 | 6 | 12 | 12 |

TR-12-163

STEP 4

Remove sticker numbers "7" and "8" from the sheet and place them on the cables coming from the left chest window. The numbers can attach to either cable.

Labeling the Electrical Components

5

No 9: Chest spotlight

No 10: Chest spotlight

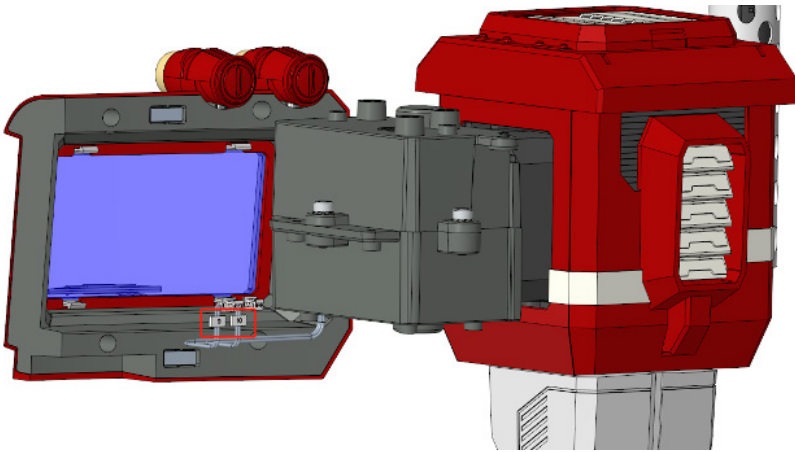
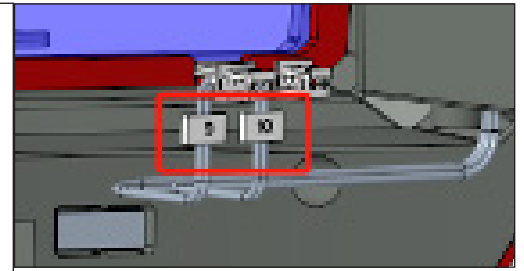

| | | | |
|---|---|----|----|
| 1 | 1 | 7 | 7 |
| 2 | 2 | 8 | 8 |
| 3 | 3 | 9 | 9 |
| 4 | 4 | 10 | 10 |
| 5 | 5 | 11 | 11 |
| 6 | 6 | 12 | 12 |

TR-12-163

STEP 5

Remove sticker numbers "9" and "10" from the sheet and place them on the cables coming from the right chest window. Again, the numbers can attach to either cable.

6

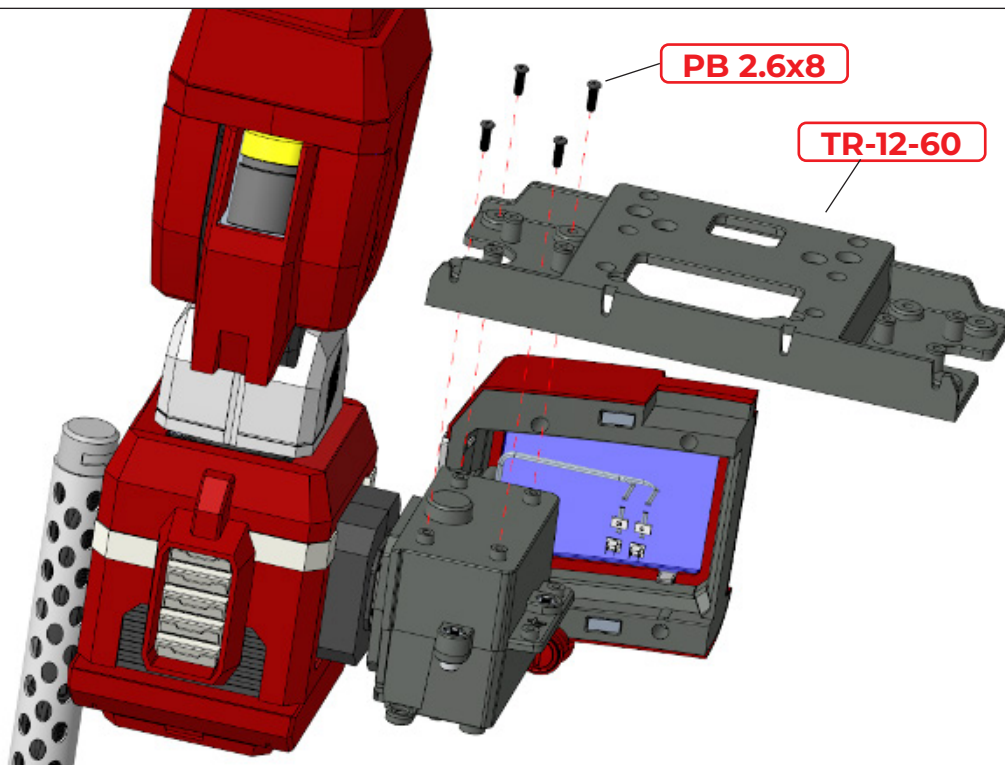

STEP 6

Attach TR-12-60 to the underside of the right arm/chest window assembly. Secure it using 4x PB 2.6x8 mm screws.

Attaching the Left and Right Arms, Chest and Back

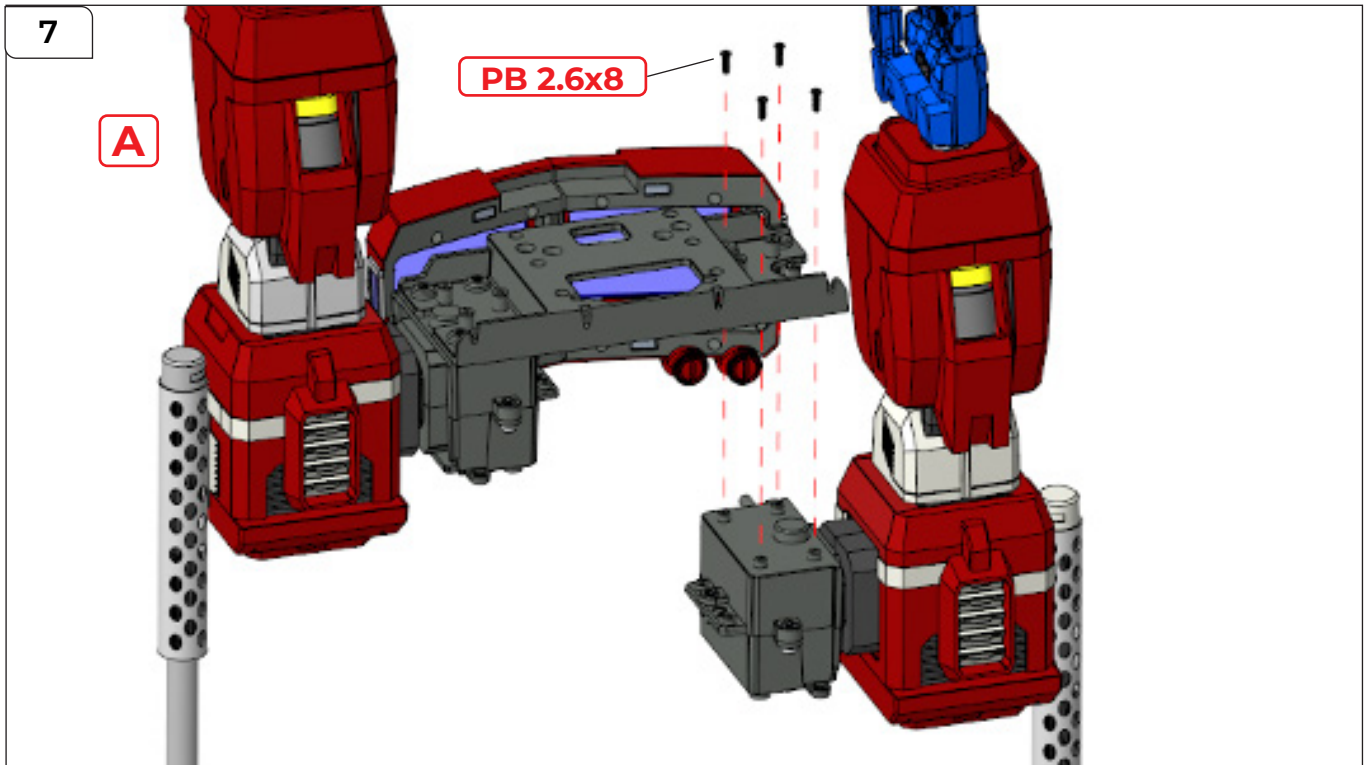

STEP 7

Attach the assembly to the other arm in the same way using another 4x PB 2.6x8mm screws.

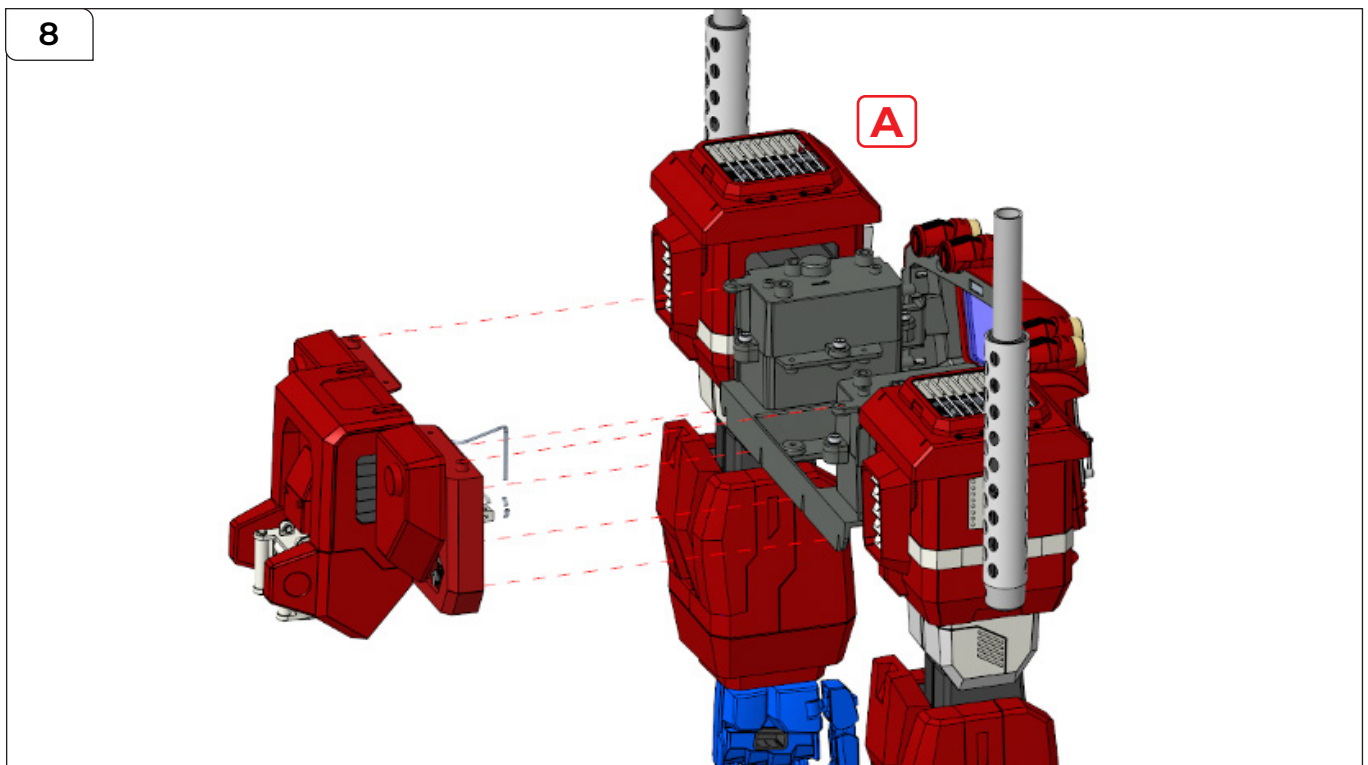

STEP 8

Attach the back section to the assembly using the six fixing points shown.

Attaching the Left and Right Arms, Chest and Back

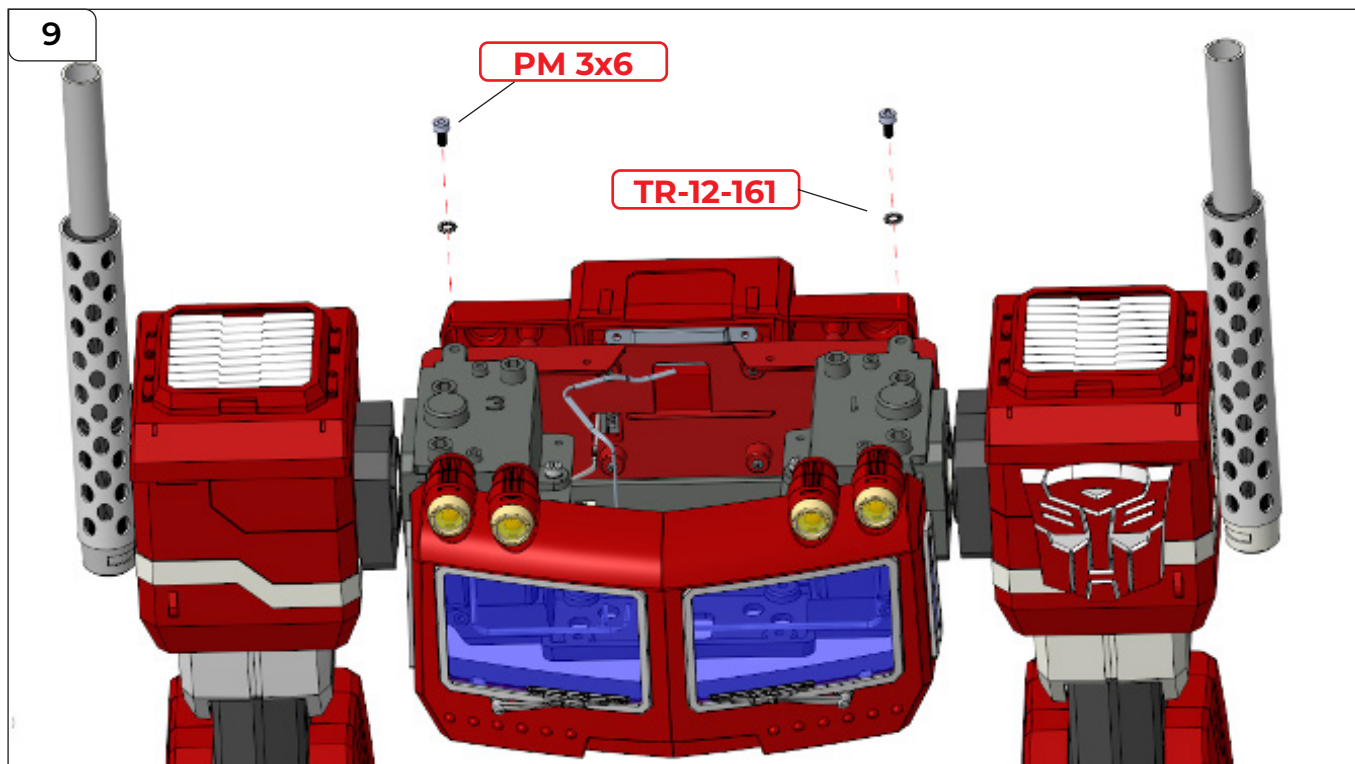

STEP 9

Thread TR-12-161 onto PM 3x6 screws and use them to secure the back section in place.

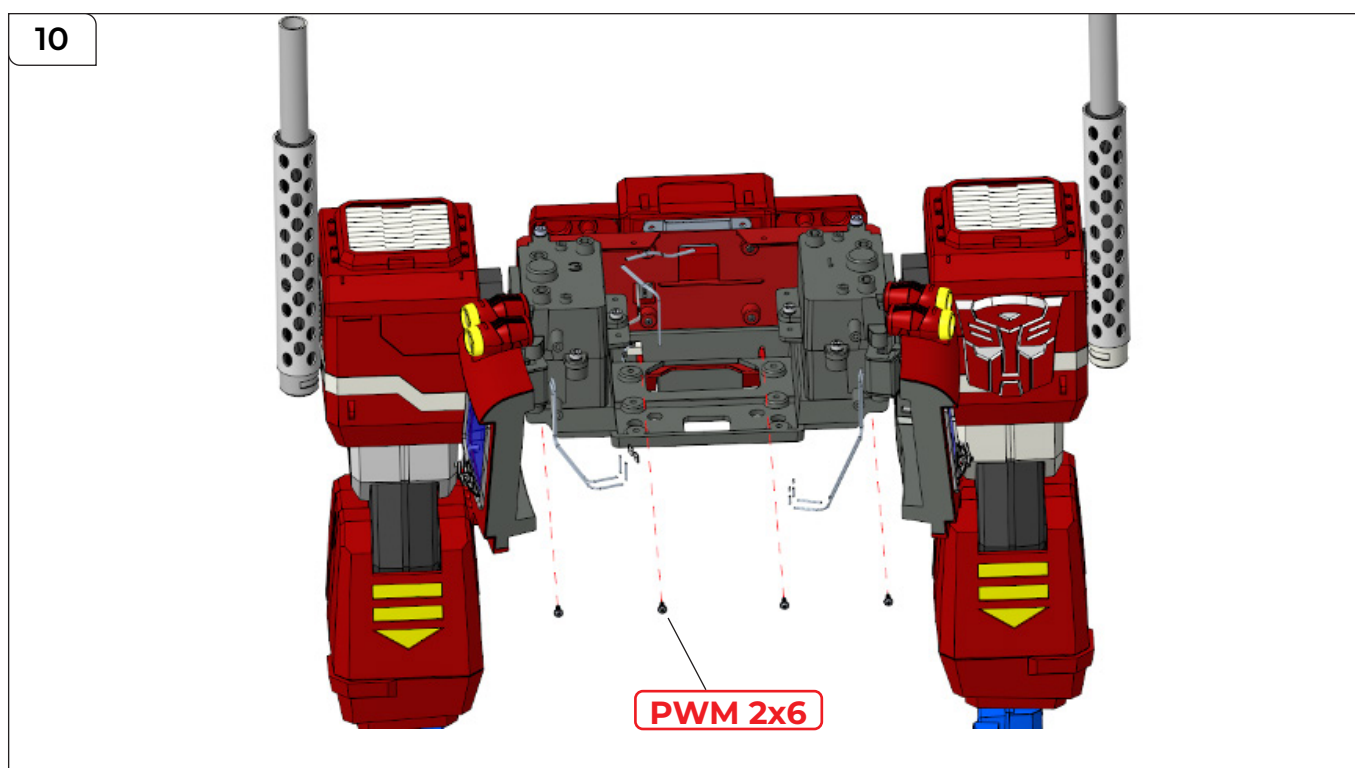

STEP 10

Continue to secure the back section in place using 4x PWM 2x6 mm screws.

Attaching the Left and Right Arms, Chest and Back

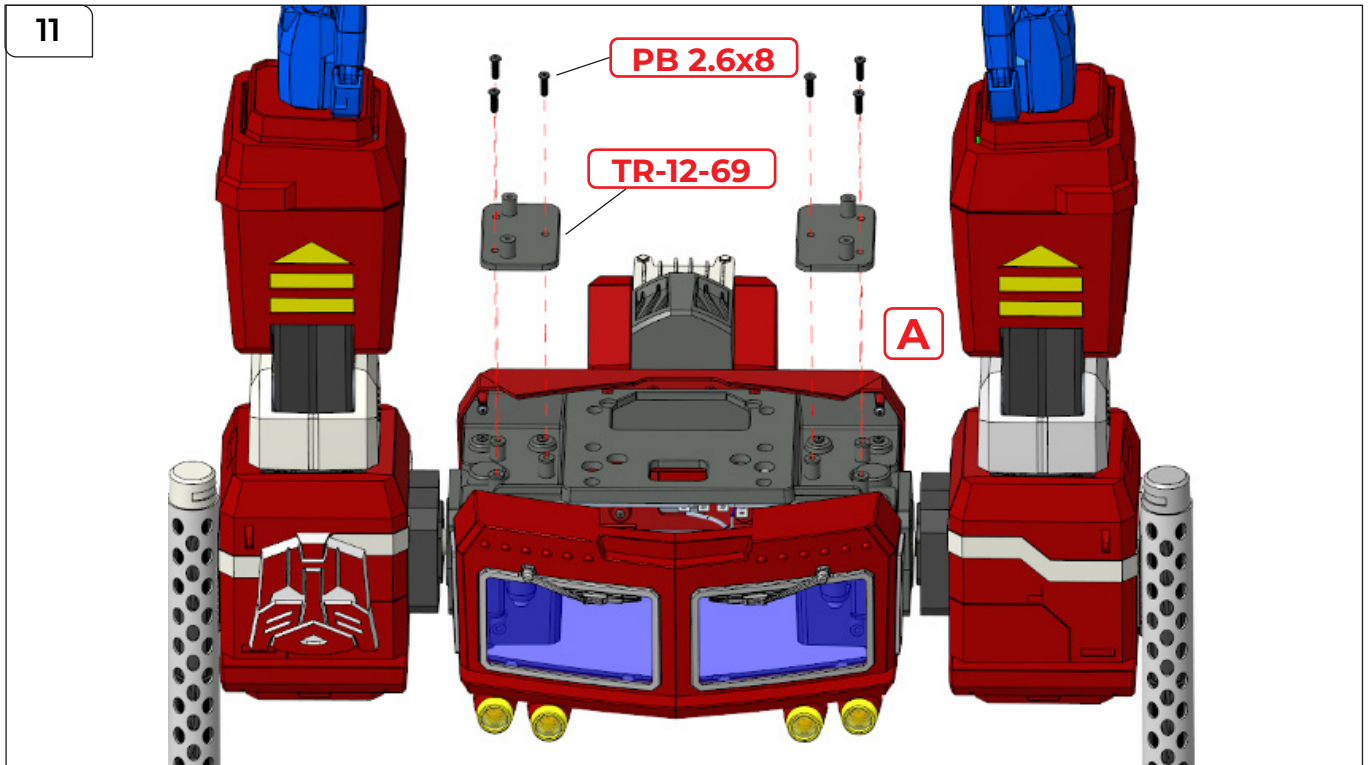

STEP 11

Attach 2x TR-12-69 and secure them using 3x PB 2.6x8 mm screws on each side.

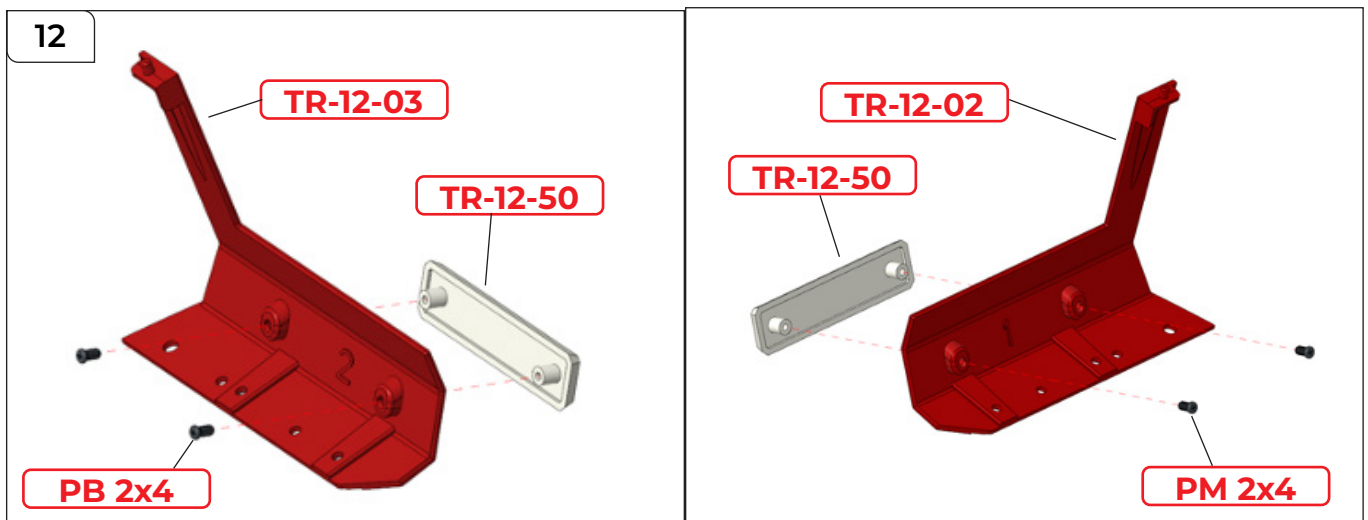

STEP 12

Take TR-12-03 and TR-12-02, then attach TR-12-50 to each one as shown. Secure with 2x PM 2x4 mm screws on each side.

Attaching the Left and Right Arms, Chest and Back

13

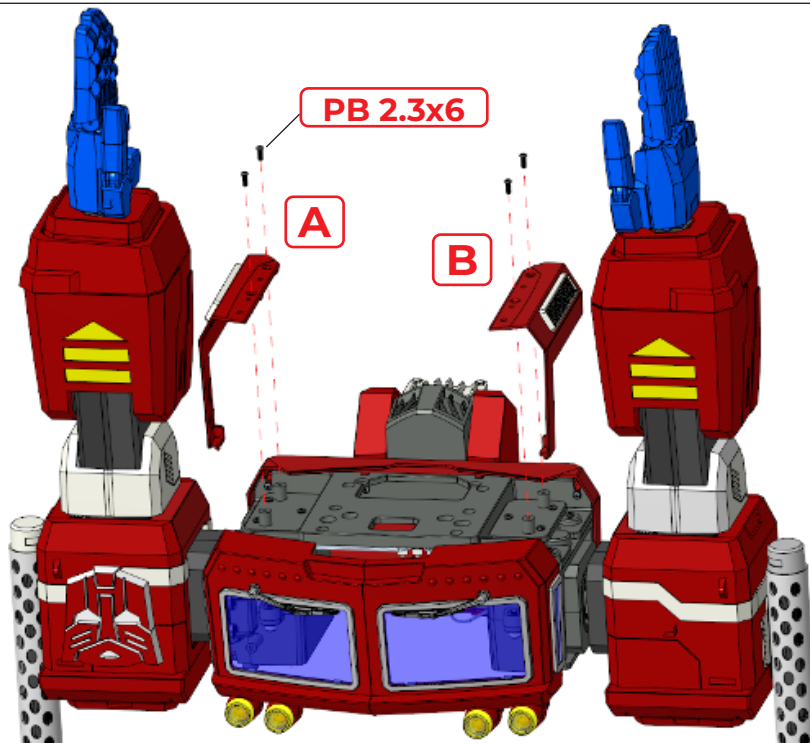

STEP 13

Fit the two assemblies you've just made to the underside of the chest section. Secure them using 2x PB 2.3x6 mm screws on each side.

14

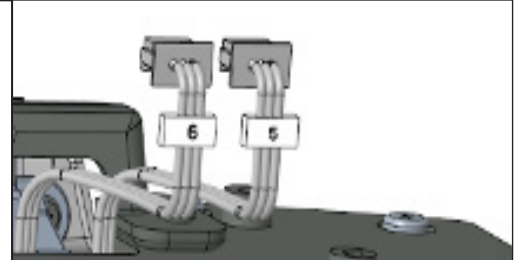
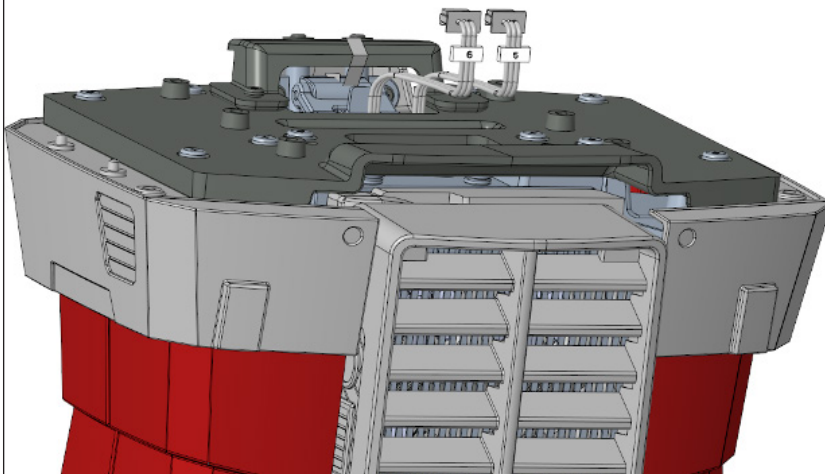

| | | | |
|---|---|----|----|
| 1 | 1 | 7 | 7 |
| 2 | 2 | 8 | 8 |
| 3 | 3 | 9 | 9 |
| 4 | 4 | 10 | 10 |
| 5 | 5 | 11 | 11 |
| 6 | 6 | 12 | 12 |

TR-12-163

STEP 14

Label the two cables coming from the body section "5" and "6". Number "5" operates the left footlight. Number "6" operates the right footlight.

Attaching the Chest and Legs

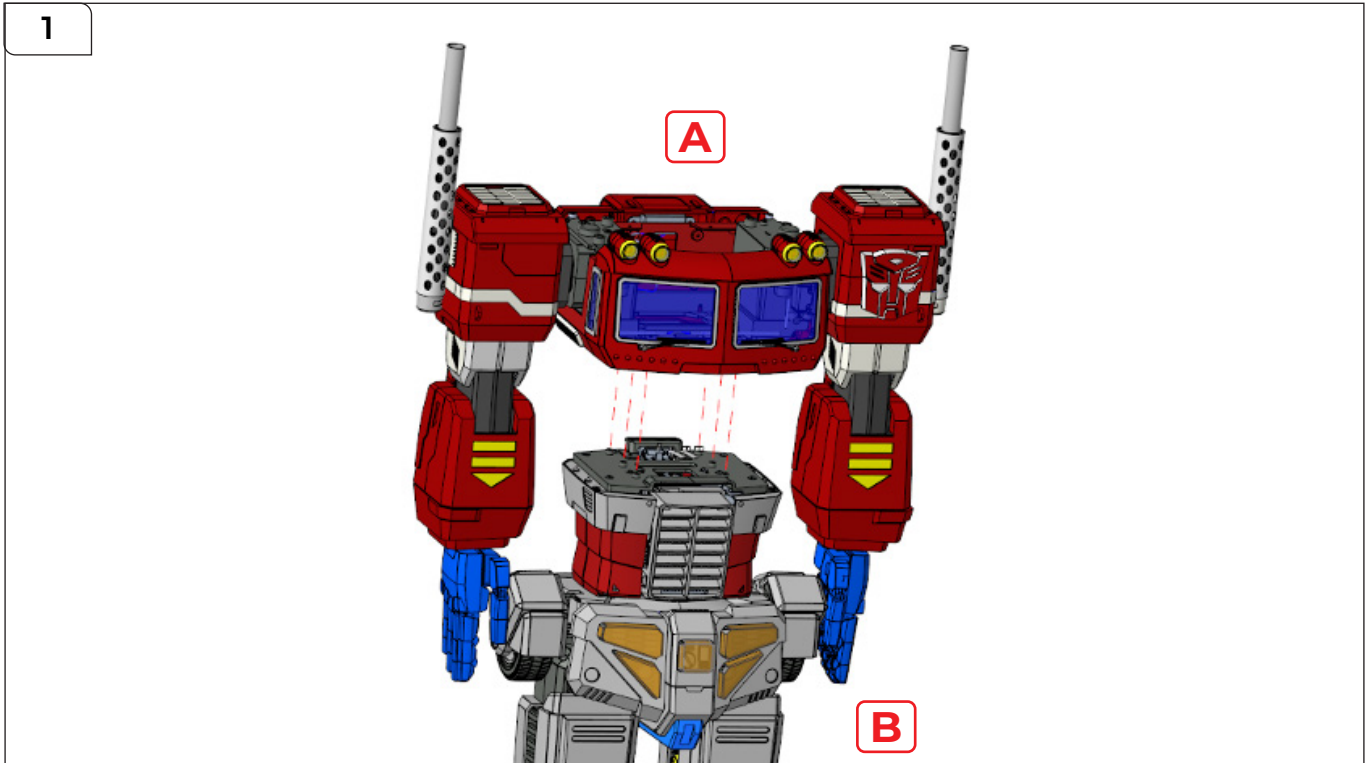

STEP 1

Pass the two footlight cables ("5" and "6") into the chest section as you attach the chest and body sections together.

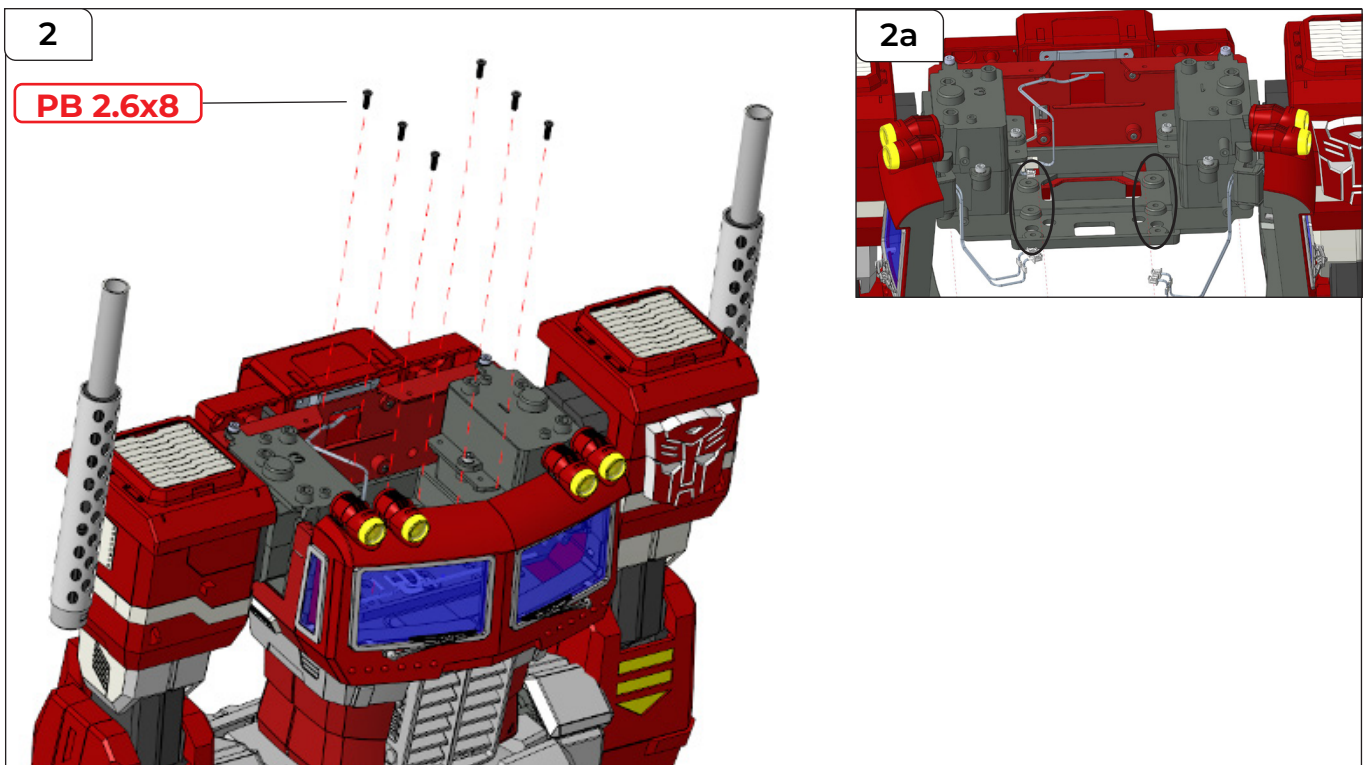

STEP 2

Secure the sections together using 6x PB 2.6x8 mm screws (the fixing points are highlighted in 2a).

Connecting the Cables to the Circuit Board and Attaching the Chest Matrix

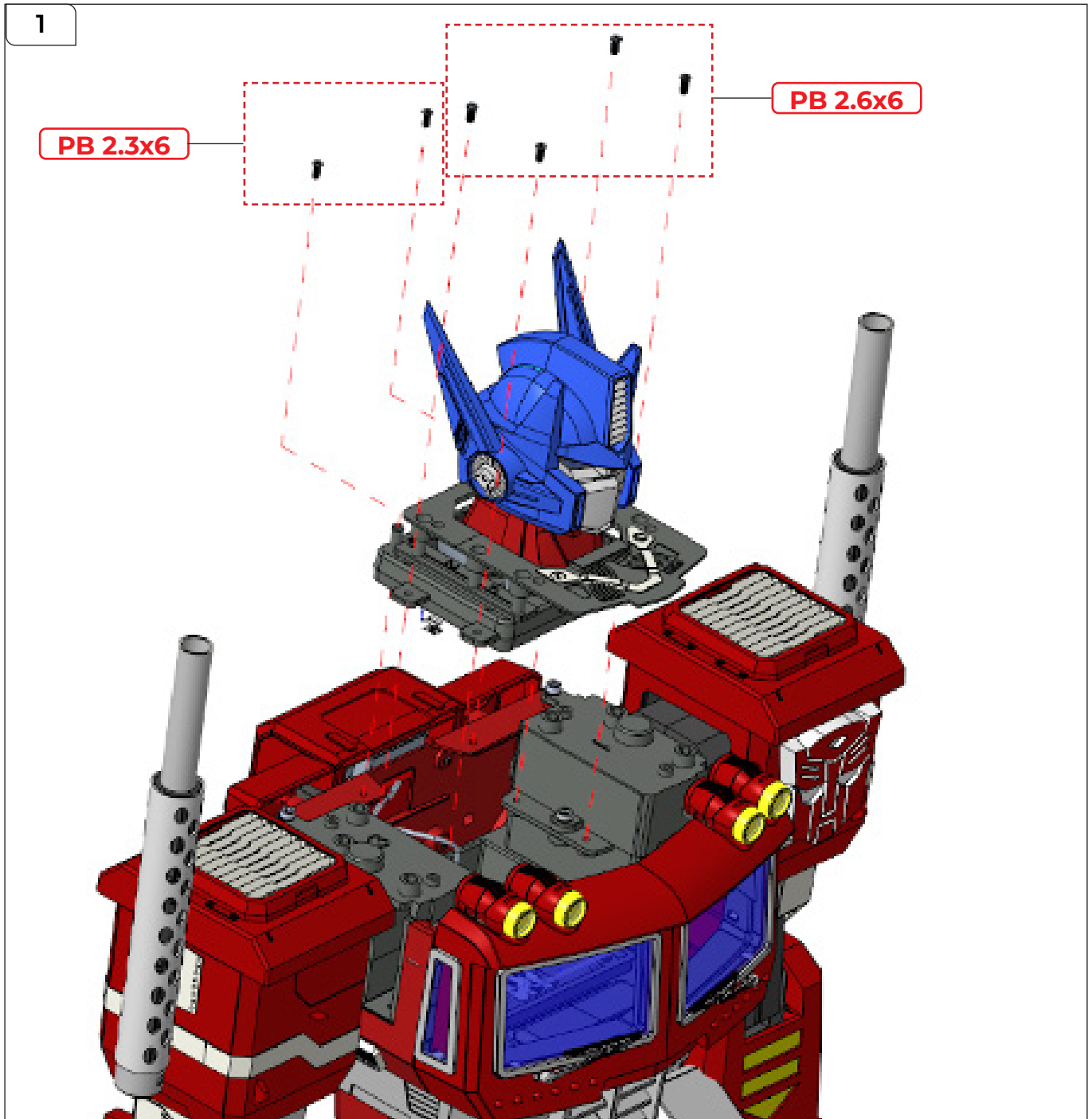

STEP 1

Please pay attention!

In the next steps, you will plug the cables within the chest section into the circuit board. The images show the head section being attached before the cables are plugged in. However, you might find it easier to complete steps 2-5, before coming back to step 1 to plug in the cables from the head and then fitting it.

When you are ready to attach the head to the body, support the head while you plug the cables into the corresponding sockets on the circuit board. Try not to pull on the plugs as the wiring can be fragile. Once the three head cables are connected, align the screw holes and secure using 2x PB 2.3x6 mm screws at the back and 4x PB 2.6x6 mm screws on the sides.

Connecting the Cables to the Circuit Board and Attaching the Chest Matrix

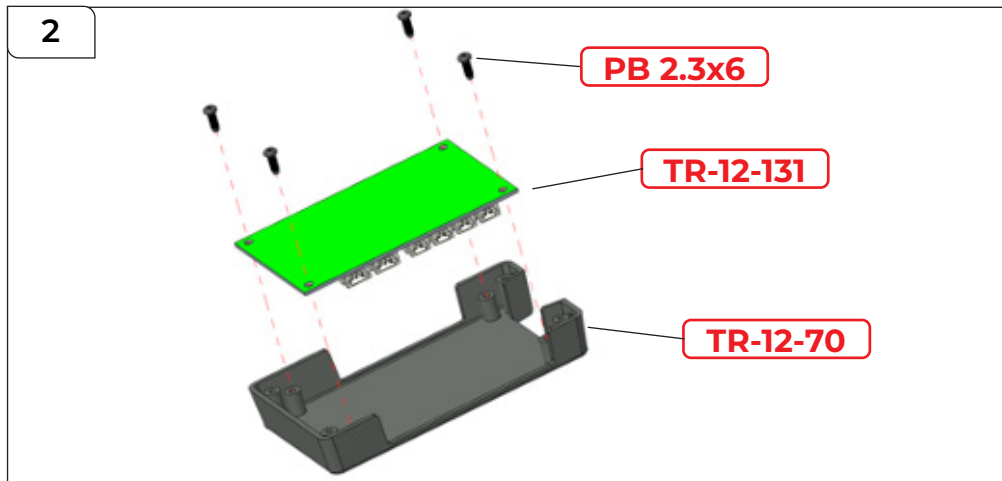

STEP 2

Fit TR-12-131 to TR-12-70 and secure with 4x PB 2.3x6 mm screws.

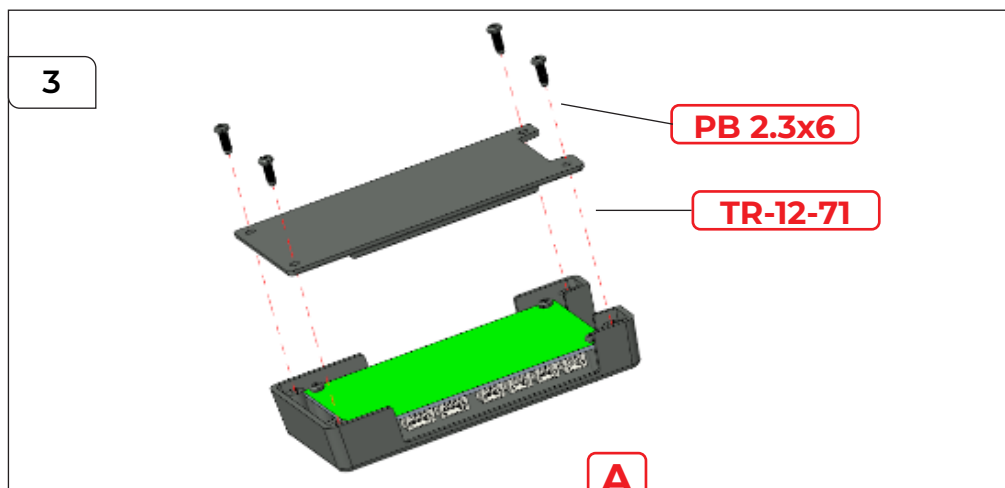

STEP 3

Fit TR-12-71 to the assembly and secure with 4x PB 2.3x6 mm screws.

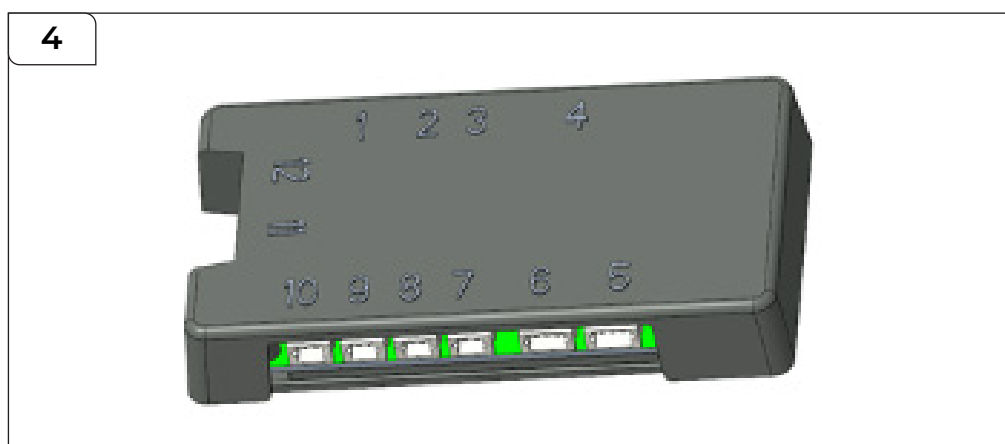

STEP 4

The circuit board is now ready to be installed in the chest cavity.

Connecting the Cables to the Circuit Board and Attaching the Chest Matrix

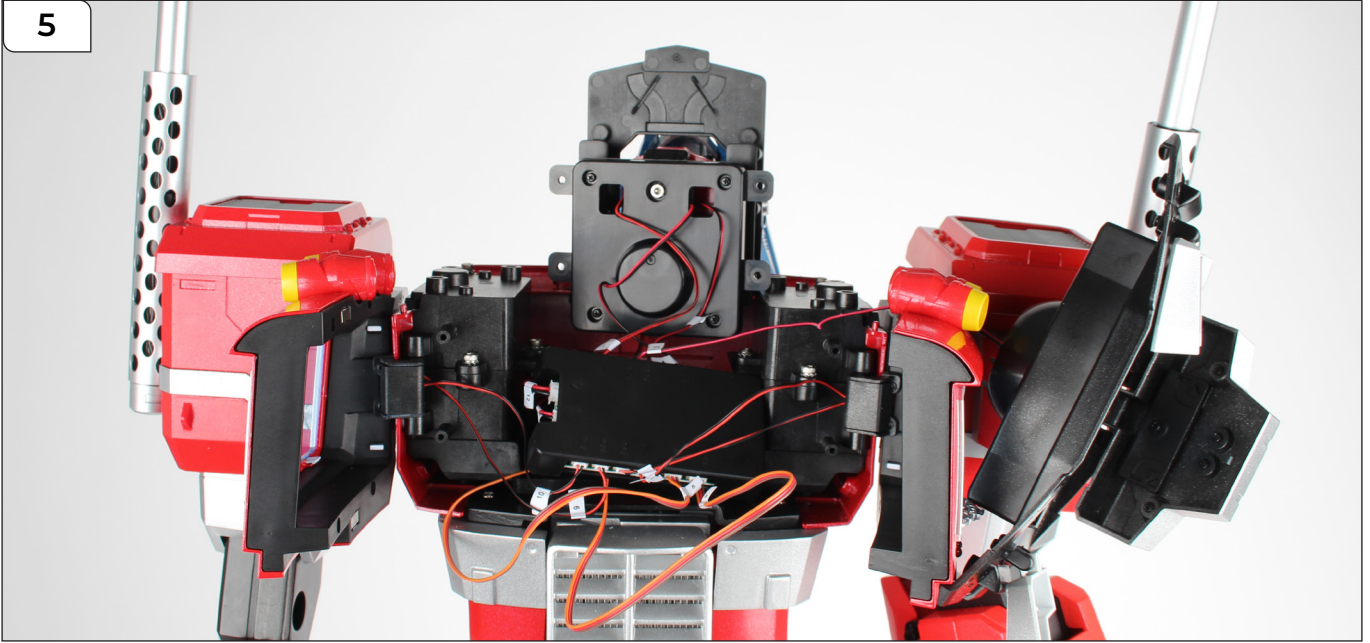

STEP 5

Hold the circuit board in front of the chest cavity as you plug in the cables to their corresponding sockets. Match the number on the cable to the number on the socket. There are 12 cables and 12 sockets to connect (including the head). Feed the circuit board into the chest cavity, tidying the cables so everything fits neatly in place. Keep the sockets for the head clear to aid plugging in the head cables, then go back to step 1 to fit the head cables and the head into place. Finally, fit the Matrix section to the chest, covering the circuit board, and secure it in place using 4x PB 2.3x6 mm screws.

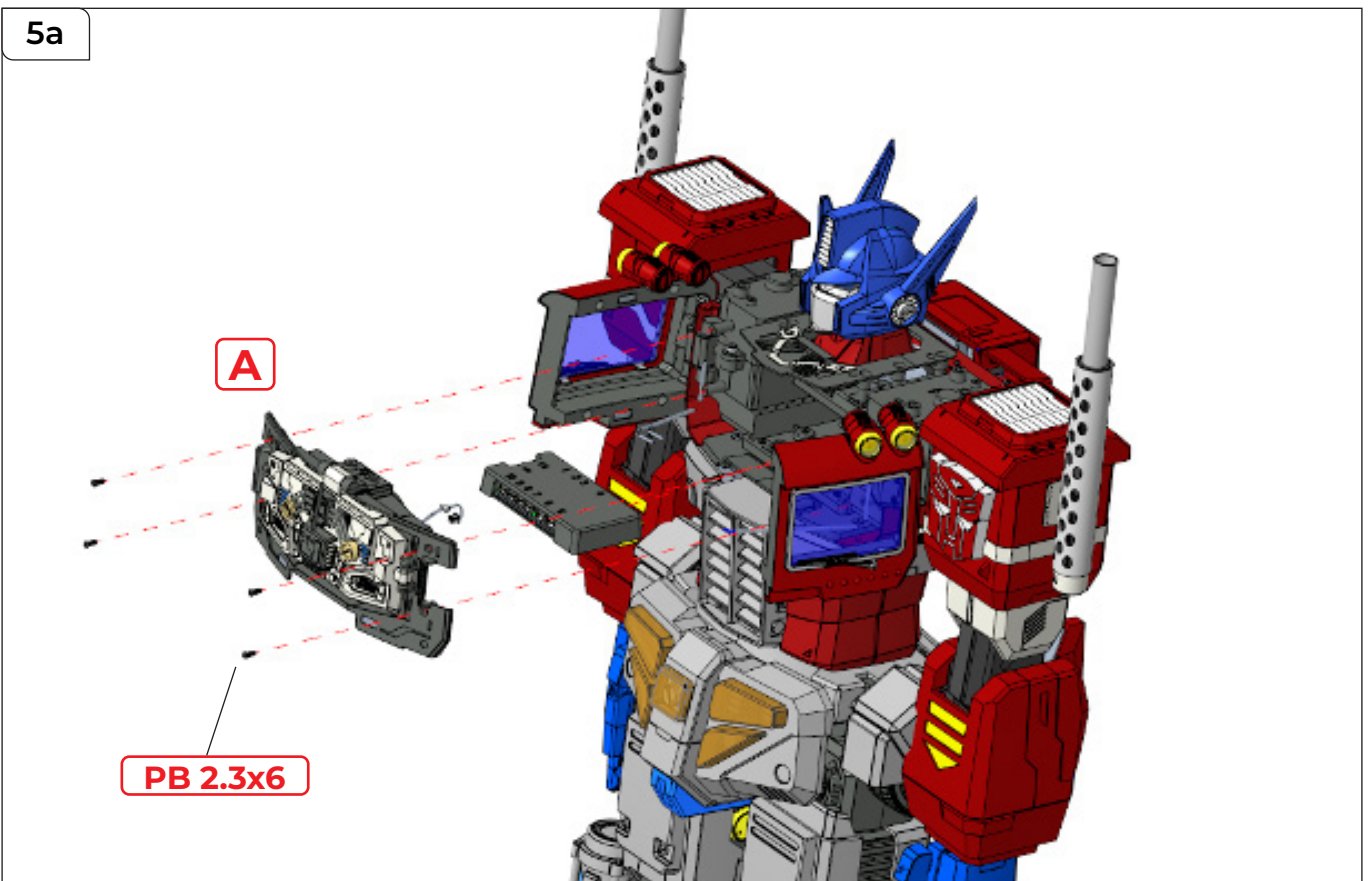

Connecting the Cables to the Circuit Board and Attaching the Chest Matrix.

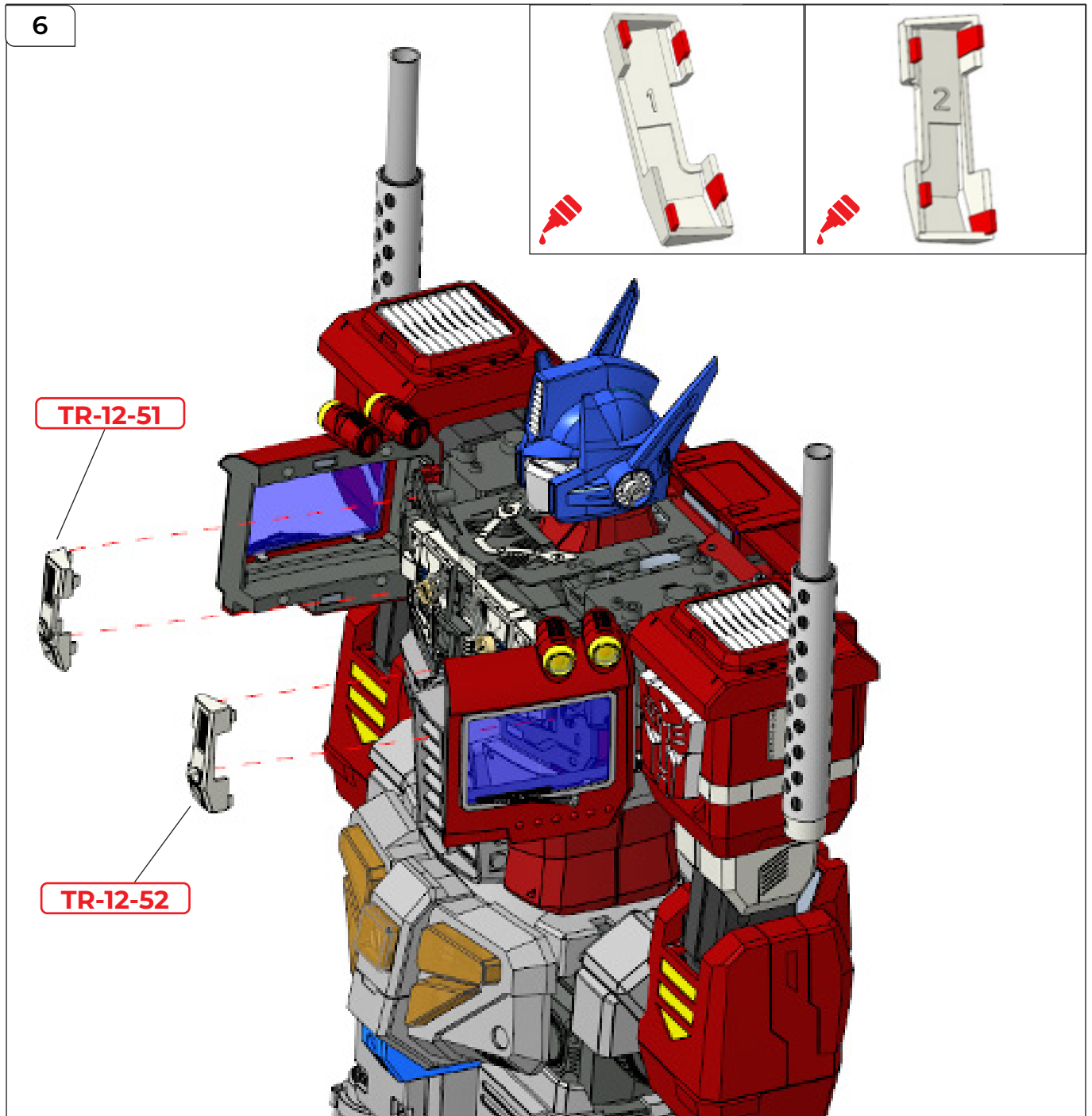

STEP 6

Take TR-12-51 and TR-12-52, apply a little glue, then fit them to the front of the Matrix as shown.

Final Parts for the Neck and Shoulders

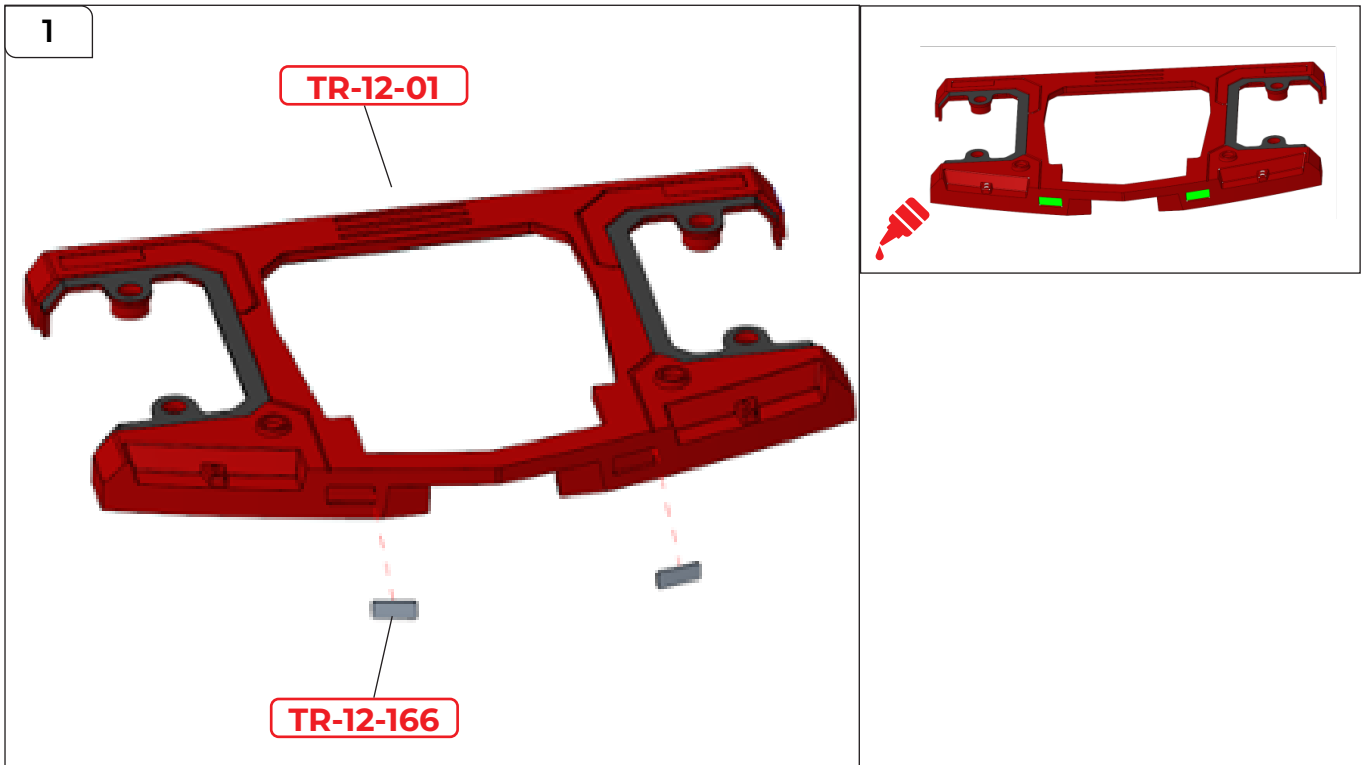

STEP 1

Apply a little glue to TR-12-01 and fit 2x TR-12-166 into the recesses.



STEP 2

Angle the assembly slightly to face downwards so that it can fit over the head in the orientation shown.

Final Parts for the Neck and Shoulders

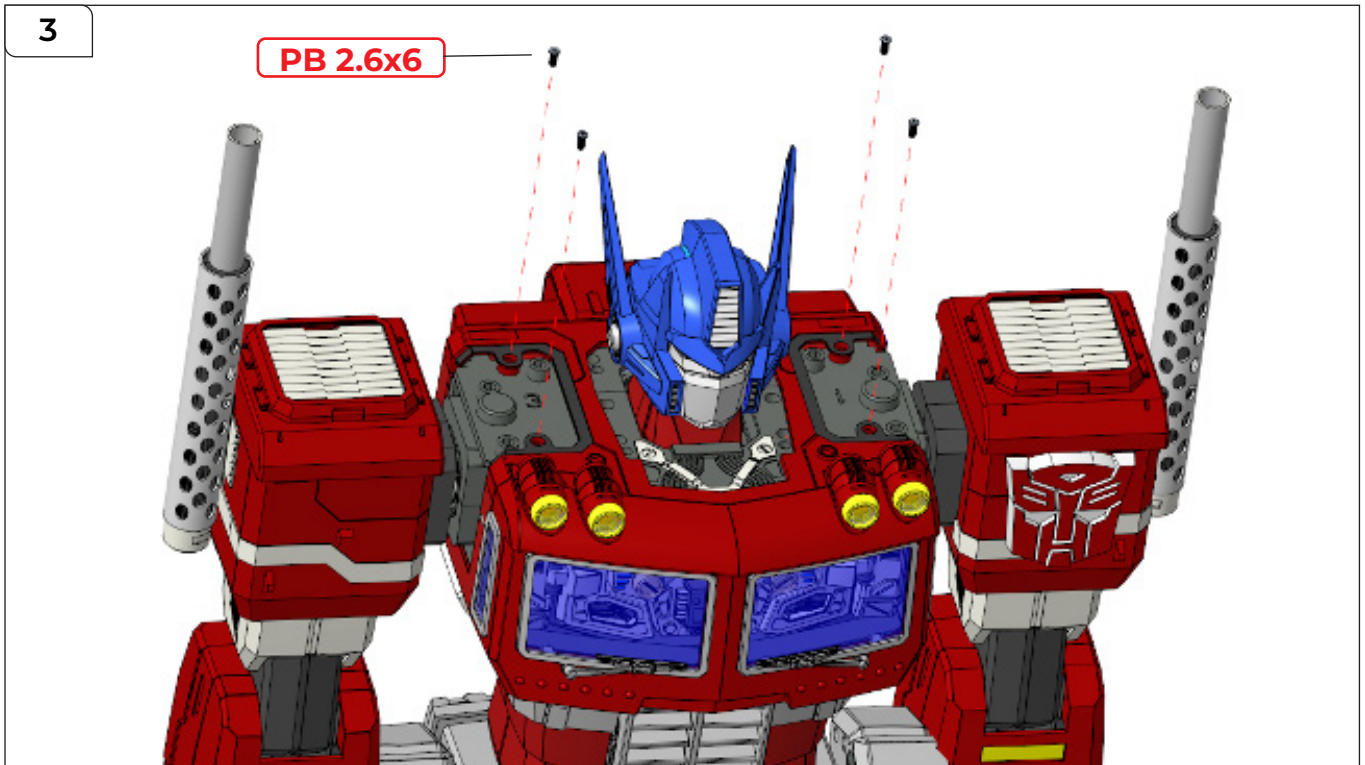

STEP 3

Secure it in place using 4x PB 2.6x6 mm screws.



STEP 4

Take TR-12-42 and TR-12-43. Apply a little glue to the pins before attaching parts TR-12-49 and TR-12-48.

Final Parts for the Neck and Shoulders

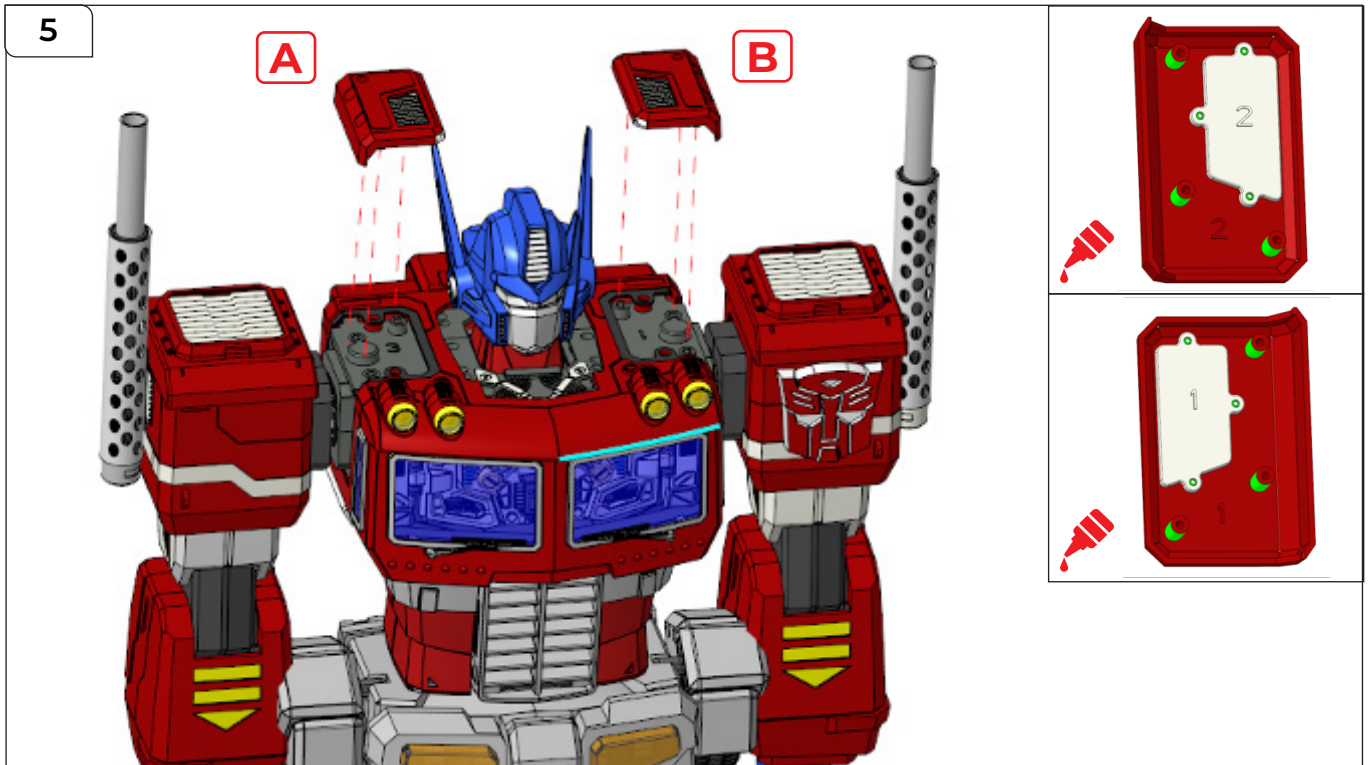

STEP 5

Apply a little more glue to the posts as shown before fitting the assemblies to the shoulders.

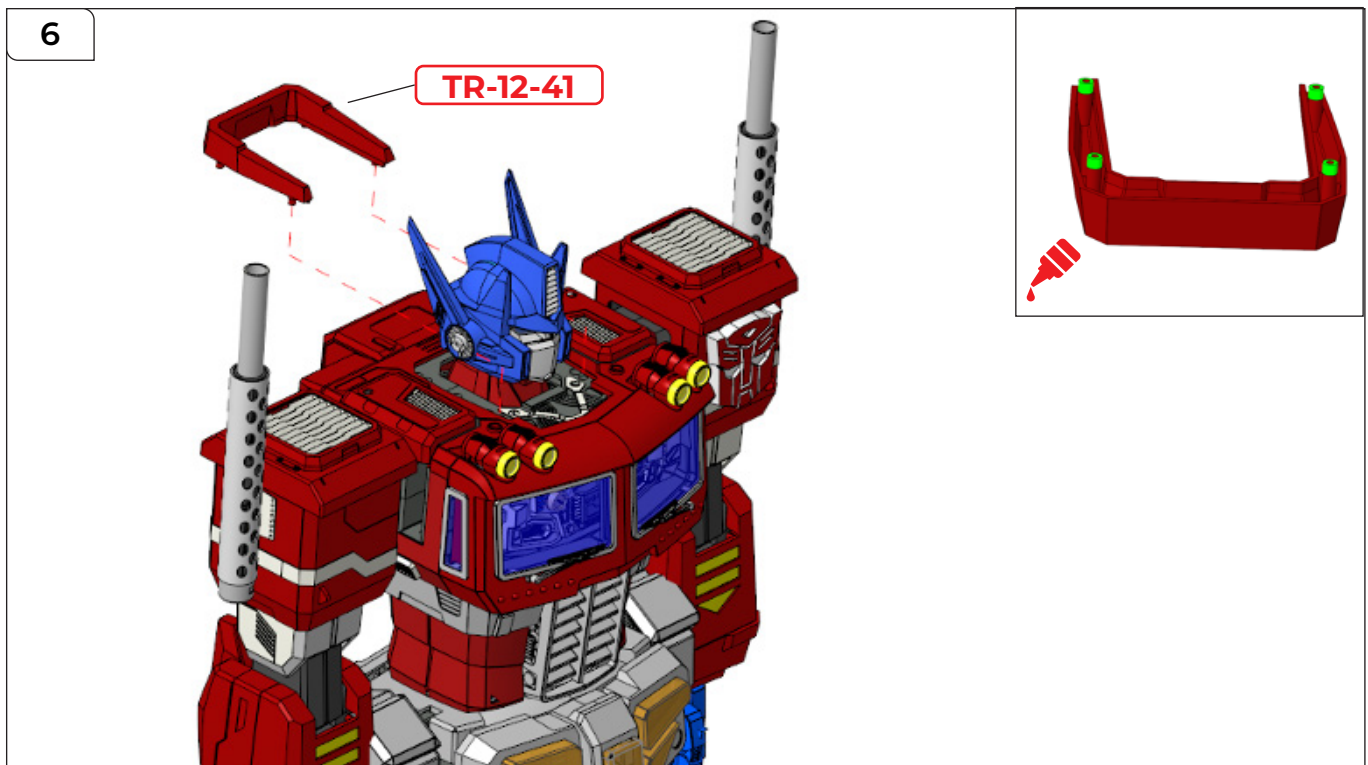

STEP 6

Finally, apply a drop of glue to TR-12-41 and fit it around the neck as shown.

Final Parts for the Neck and Shoulders

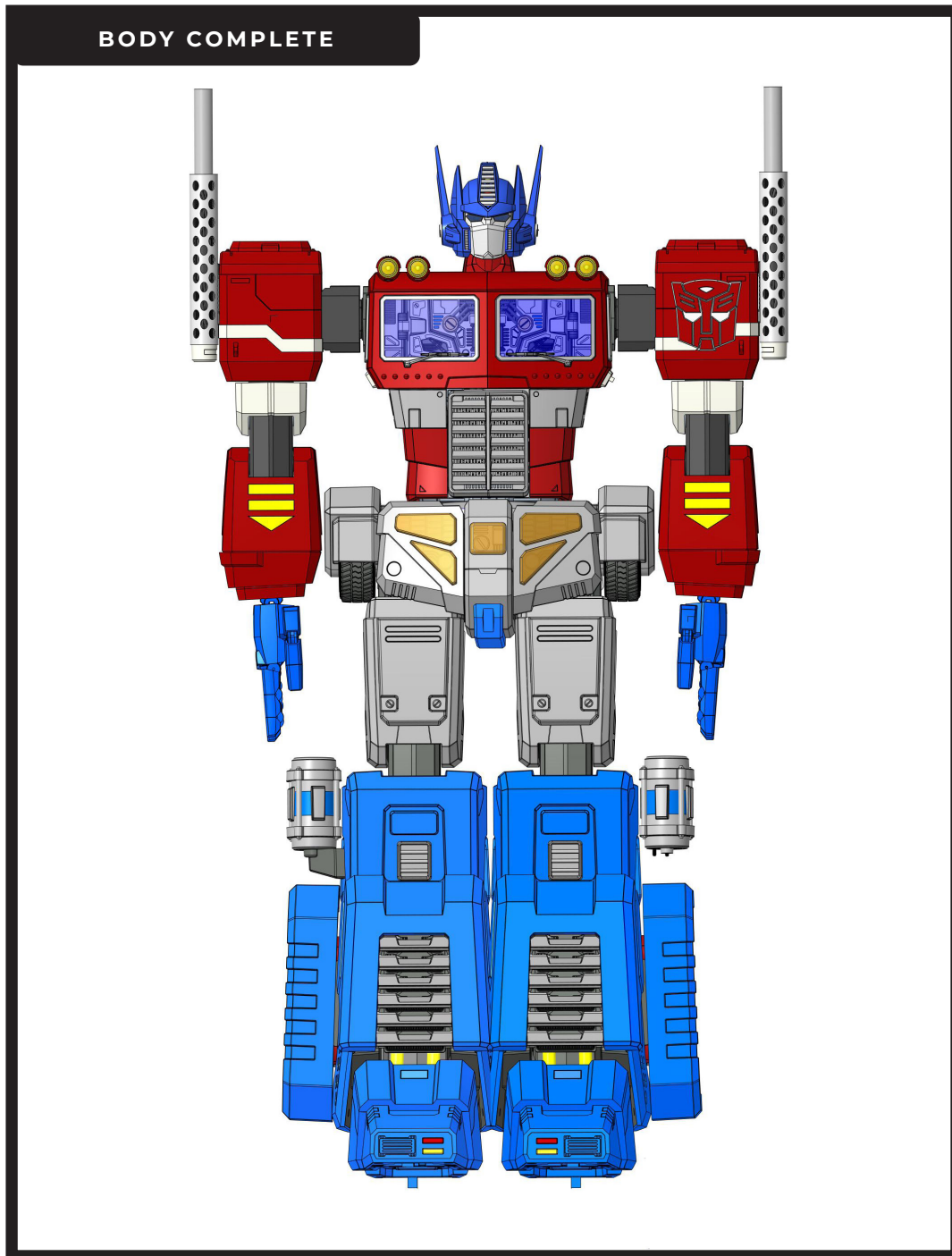

Your model of Optimus Prime is now complete!

For assistance with assembling the weapons and posing your model, please visit the download centre where you'll find our demonstration videos.

Don't forget, when you buy any model from Agora Models you automatically become a member of the Advantage Club, qualifying for a host of member benefits, including a FREE PACK 1 of your next kit. Please visit our website for more details.